



Space engineering

Radio frequency and modulation

Foreword

This Standard is one of the series of ECSS Standards intended to be applied together for the management, engineering and product assurance in space projects and applications. ECSS is a cooperative effort of the European Space Agency, national space agencies and European industry associations for the purpose of developing and maintaining common standards. Requirements in this Standard are defined in terms of what shall be accomplished, rather than in terms of how to organize and perform the necessary work. This allows existing organizational structures and methods to be applied where they are effective, and for the structures and methods to evolve as necessary without rewriting the standards.

This Standard has been prepared by the ECSS-E-ST-50-05C Working Group, reviewed by the ECSS Executive Secretariat and approved by the ECSS Technical Authority.

Disclaimer

ECSS does not provide any warranty whatsoever, whether expressed, implied, or statutory, including, but not limited to, any warranty of merchantability or fitness for a particular purpose or any warranty that the contents of the item are error-free. In no respect shall ECSS incur any liability for any damages, including, but not limited to, direct, indirect, special, or consequential damages arising out of, resulting from, or in any way connected to the use of this Standard, whether or not based upon warranty, business agreement, tort, or otherwise; whether or not injury was sustained by persons or property or otherwise; and whether or not loss was sustained from, or arose out of, the results of, the item, or any services that may be provided by ECSS.

Published by: ESA Requirements and Standards Division
ESTEC, P.O. Box 299,
2200 AG Noordwijk
The Netherlands

Copyright: 2009 © by the European Space Agency for the members of ECSS

Change log

ECSS-E-50-05A 14 November 2007	First issue
ECSS-E-50-05B	Never issued
ECSS-E-ST-50-05C 31 July 2008	<p>First issue</p> <p>The main changes between the previous version and this one are:</p> <ul style="list-style-type: none">• The changes that occurred in the ITU radio regulations or in the SFCG frequency management procedures since the date of issue of ECSS-E-50-05A have been reflected in the present standard:<ul style="list-style-type: none">— Addition of the 25,5 GHz -27,0 GHz band;— Improved status of the 7145 MHz -7235 MHz band;— Deletion of the 14 GHz and 16 GHz bands;— Revised conditions for protection of radio astronomy;— New conditions for the 8400 MHz - 8450 MHz band (max. 25-dB bandwidth instead of spectral mask).• The changes that occurred in CCSDS have been reflected in the present standard:<ul style="list-style-type: none">— Addition of QPSK bit mapping convention;— Addition of GMSK for the 32 GHz band;— Addition of frequency stability requirement for SP-L and suppressed carrier modulations;— Relaxation of phase and amplitude imbalance requirements for suppressed carrier modulations;— Addition of 32/34 GHz and 7/26 GHz turn-around ratios;— Addition of baseband OQPSK filtering for high rates and analogue implementation;— Alignment of SRRC roll-off factor for 8PSK (0,35 and 0,25 in ECSS-E-50-05A) with CCSDS (0,35 and 0,5).• In addition, several editorial mistakes have been corrected and the understanding has been improved where needed:<ul style="list-style-type: none">— Replacement of 8PSK TCM post-amplifier shaping figure with the correct one;— Clarification of symbol rate use for SP-L, 8PSK TCM and SRRC-OQPSK modulations;— Deletion of references to ESA PSS standards;— Clarification of several 8PSK TCM clauses;— Correction and alignment of SRRC formulas of OQPSK with those of 8PSK, and deletion of SRC formulas;— Addition of the non deep space bands, that had been taken out from ECSS-E-50-05A by mistake, to the phase noise clauses.

ECSS-E-ST-50-05C Rev. 1 6 March 2009	<p>First issue revision 1</p> <p>Changes with respect to version C (31 July 2008) are identified with revision tracking.</p> <p>Main changes are:</p> <ul style="list-style-type: none">• 5.5.1.3a NOTE: added missing hyphen in "SA.1157-1"• Table 6-1: reformatted table that the word "Telecommand" reads properly as one word in the cell• 6.2.3.4a: removed the surplus comma at the end of $T_{chs} = 2T_s$• 9.1.a: corrected the expression for a_k to show correct superscript and subscript fonts: $a_k = (-1)^k d_k d_{k-1}$• 9.2.6.2c.: corrected expression to show correct subscript fonts for R_{ES} and R_s: The resulting overhead for computing R_{ES} from R_s shall be 1,5 and 1,2 for $SEF = 2$ and for $SEF = 2,5$ respectively ($R_{ES} = 1,5 R_s$ and $R_{ES} = 1,2 R_s$ respectively)
---	--

Table of contents

Change log	3
Introduction	9
1 Scope	10
2 Normative references	11
3 Terms, definitions and abbreviated terms	12
3.1 Terms from other standards	12
3.2 Terms specific to the present standard	12
3.3 Abbreviated terms	14
4 Frequency allocations, assignment and use	17
4.1 Frequency allocations to the Space Operation, Space Research and Earth Exploration-Satellite services	17
4.1.1 Overview.....	17
4.1.2 Frequency bands allocated to the Space Radiocommunications services	17
4.2 Specific conditions for the use of certain frequency bands	19
4.2.1 2 025 MHz – 2 120 MHz and 2 200 MHz – 2 300 MHz bands	19
4.2.2 8 025 MHz – 8 400 MHz band.....	21
4.2.3 8 400 MHz - 8 450 MHz band.....	21
4.2.4 8 450 MHz – 8 500 MHz band.....	21
4.2.5 25,5 GHz – 27,0 GHz, 37,0 GHz – 38 GHz and 40,0 GHz – 40,5 GHz bands.....	21
4.3 Frequency assignment procedure	22
4.3.1 Choice of frequencies.....	22
4.3.2 Advance publication, coordination and notification of frequencies	23
5 Transmitted signals	24
5.1 Turnaround frequency ratio for coherent transponders	24
5.1.1 Generation of the transmitted carrier.....	24
5.1.2 Band pairs	24
5.2 Carrier frequency stability.....	26

5.2.1	Spacecraft transmitter	26
5.2.2	Spacecraft receiver.....	27
5.2.3	Ground station equipment	27
5.3	Polarization.....	28
5.4	Occupied bandwidth considerations.....	28
5.5	Emissions	30
5.5.1	Unwanted emission power level	30
5.5.2	Cessation of emissions.....	34
5.5.3	Power flux density limits at the Earth's surface	34
5.5.4	Power flux density limits at the GSO in the 25,5 GHz - 27,0 GHz band.....	35
5.5.5	Power limits for Earth station emissions.....	36
5.5.6	Time limitations on transmissions.....	37
6	Modulation	38
6.1	Phase modulation with residual carriers.....	38
6.1.1	Application	38
6.1.2	Modulating waveforms.....	38
6.1.3	PCM waveforms and data rates	39
6.1.4	Use of subcarriers	41
6.1.5	Data transition density	43
6.1.6	Carrier modulation index	44
6.1.7	Sense of modulation.....	44
6.1.8	Modulation linearity.....	44
6.1.9	Residual amplitude modulation	44
6.1.10	Carrier phase noise	45
6.1.11	Residual carrier, out-of-band emission and discrete spectral lines	45
6.2	Suppressed carrier modulation	46
6.2.1	Application and modulation schemes	46
6.2.2	Modulating waveforms.....	47
6.2.3	Carrier modulation	47
6.2.4	Data transition density	53
6.2.5	Symbol rate stability	53
6.2.6	Carrier phase noise	53
6.2.7	Carrier suppression, out-of-band emission and discrete spectral lines	53
6.3	Spectral roll-off	54
7	Link acquisition procedures	55
7.1	Space-Earth	55

7.1.1	Normal operation	55
7.1.2	Alternative mode of operation.....	55
7.1.3	Coherent mode.....	55
7.2	Earth-space	56
7.2.1	2 025 MHz - 2 110 MHz category A	56
7.2.2	2 110 MHz - 2 120 MHz category B	57
7.2.3	7 145 MHz - 7 190 MHz category B	57
7.2.4	7 190 MHz – 7 235 MHz category A.....	57
8	RF interface control.....	59
8.1	RF interface control documents	59
8.2	Spacecraft-Earth station interface control document.....	59
8.2.1	Overview.....	59
8.2.2	Process.....	59
8.3	Link budget tables	60
8.3.1	General.....	60
8.3.2	Parameters	60
8.4	Spacecraft-ground network compatibility test.....	63
9	GMSK and 8PSK TCM modulation formats	65
9.1	GMSK modulation format	65
9.2	8PSK TCM modulation format.....	66
9.2.1	General principles.....	66
9.2.2	4 dimensional 8PSK-TCM encoder	66
9.2.3	Differential encoders for SEF = 2 and 2,5	67
9.2.4	Trellis encoder structure	68
9.2.5	Constellation mapper for 4 dimensional 8PSK-TCM	68
9.2.6	Channel filtering.....	70
Annex A	(normative) Spacecraft-Earth station interface control document - DRD	73
Annex B	(informative) Cross-support from other networks	74
Annex C	(informative) Protection of Ariane-5 RF system	75
Annex D	(informative) Differences from CCSDS recommendations.....	77
Annex E	(informative) Tailoring guidelines.....	80
Bibliography	81

Figures

Figure 4-1: Maximum allowable bandwidth in the band 8 400 MHz - 8 450 MHz	22
Figure 6-1: PCM waveforms and symbol duration definition	40
Figure 6-2: Symbol rate reference point.....	41
Figure 6-3: QPSK/OQPSK constellation mapping	48
Figure 6-4: OQPSK post-amplifier filter transfer function	51
Figure 6-5: Spectral emission masks for telemetry transmission at symbol rates above 60 ksps	54
Figure 8-1: Parameter distributions and their equations	62
Figure 9-1: General principle of the 4D-8PSK TCM modulator	67
Figure 9-2: Codes to eliminate 22,5° phase ambiguity on carrier synchronization	68
Figure 9-3: Representation of a 64 state L=7, rate 3/4 systematic trellis encoder	68
Figure 9-4: Constellation mapper for SEF = 2.....	69
Figure 9-5: Constellation mapper for SEF = 2,5.....	69
Figure 9-6: Transmit structure for baseband, square root raised-cosine shaping.....	71
Figure 9-7: Transfer function for a 4 poles/2 zeros elliptic filter.....	71
Figure 9-8: Transmit structure for post-amplifier shaping.....	72

Tables

Table 4-1: Frequency allocations to the Space Operation, Space Research and Earth Exploration-Satellite services.....	18
Table 5-1: Turnaround frequency ratios for coherent transponder operation.....	25
Table 5-2 Alternative turnaround frequency ratios for coherent transponder operation.....	26
Table 5-3: Frequency stability for spacecraft transmitters.....	26
Table 5-4: Frequency stability for spacecraft receivers.....	27
Table 5-5: Occupied bandwidth.....	29
Table 5-6: Maximum level of spurious emissions.....	30
Table 5-7: Threshold levels of interference detrimental to radio astronomy spectral line (i.e. narrow bandwidth) observations at the surface of the Earth due to terrestrial interference sources (Recommendation ITU-R RA.769-2).....	32
Table 5-8: Threshold levels of interference detrimental to radio astronomy continuum (i.e. wide bandwidth) observations at the surface of the Earth due to terrestrial interference sources (Recommendation ITU-R RA.769-2).....	33
Table 5-9: Harmful interference levels at deep space antenna sites	34
Table 5-10: Power flux density limits at the Earth's surface.....	35
Table 6-1: PCM waveforms and rates for residual carrier modulation	39
Table 6-2: Subcarriers used with phase-modulated carriers.....	41
Table 6-3: Limits of the peak modulation index.....	44
Table 6-4: PCM waveforms.....	47
Table 8-1: Probability density functions for link budgets	62

Introduction

This Standard contains requirements to ensure the following:

- Compatibility of frequency usage and modulation schemes between space agencies' spacecraft and Earth stations for the Space Operation, Space Research and Earth Exploration-Satellite services.
- Compatibility between the spacecraft and the networks that they interact with, as far as possible.
- Standardization of frequency usage and modulation schemes within the space projects.
- Conformity of spacecraft and Earth station parameters to international radio regulatory provisions (Radio Regulations of the International Telecommunication Union (ITU)) and with national regulatory provisions (e.g. national frequency plans).
- Selection of the appropriate parameters of spacecraft and Earth stations that are listed in advance of their use, thus enabling coordination with other interested parties.
- Optimization of the frequency usage and modulation schemes within the above limitation.

1

Scope

This Standard defines the radio communication techniques used for the transfer of information between spacecraft and Earth stations in both directions, and for the tracking systems used for orbit determination. It includes the following:

- frequency allocation, assignment and use;
- requirements on transmitted signals concerning, for example, spectral occupation, RF power levels, protection of other radio services;
- definition of the permissible modulation methods and parameters;
- specification of the major technical requirements relevant for the interface between spacecraft and Earth stations;
- operational aspects, such as acquisition;
- cross-support.

This Standard is applicable to all spacecraft supported by Earth stations¹ and to all controlled Earth stations operating in the Space Operation, Space Research and Earth Exploration-Satellite services as defined in the ITU Radio Regulations.²

Other space telecommunication services are not covered in this issue.

All requirements in this Standard are equally applicable to both the customer and the supplier with exception of clauses 4.3.1 and 4.3.2 which are applicable to the customer only.

Further provisions and guidance on the application of this Standard can be found, respectively, in ECSS-E-ST-50 "Communications", and in the handbook ECSS-E-HB-50A "Communications guidelines".

ECSS-E-ST-50 defines the principle characteristics of communication protocols and related services for all communication layers relevant for space communication (physical- to application-layer), and their basic relationship to each other. The handbook ECSS-E-HB-50 provides information on specific implementation characteristics of these protocols in order to support the choice of a certain communications profile for the specific requirements of a space mission. Users of the present standard are invited to consult these documents before taking decisions on the implementation of the present one.

This Standard may be tailored for the specific characteristics and constraints of a space project in conformance with ECSS-S-ST-00.

¹ This Standard is not applicable to spacecraft supported by data relay satellites.

² Under the term Earth Exploration-Satellite service, the Meteorological Satellite service is also included.

2

Normative references

The following normative documents contain provisions which, through reference in this text, constitute provisions of this ECSS Standard. For dated references, subsequent amendments to, or revisions of any of these publications, do not apply. However, parties to agreements based on this ECSS Standard are encouraged to investigate the possibility of applying the most recent editions of the normative documents indicated below. For undated references the latest edition of the publication referred to applies.

ECSS-S-ST-00-01	ECSS system – Glossary of terms
ECSS-E-ST-10-03	Space engineering – Testing
ECSS-E-ST-50	Space engineering – Communications
ECSS-E-ST-50-01	Space engineering – Space data links - Telemetry synchronization and channel coding
ITU/RR:2004 ^{3,4}	ITU Radio Regulations

³ In this Standard the relevant articles are specified after the reference name. For example, ITU/RR/1.23 refers to Article 1.23.

⁴ For possible changes to the ITU/RR, contact the responsible frequency coordinator.

3

Terms, definitions and abbreviated terms

3.1 Terms from other standards

For the purpose of this Standard, the terms and definitions from ECSS-S-ST-00-01 and ECSS-E-ST-50 apply.

3.2 Terms specific to the present standard

3.2.1 category A

category of spacecraft having an altitude above the Earth's surface of less than 2×10^6 km

3.2.2 category B

category of spacecraft having an altitude above the Earth's surface of equal to, or greater than 2×10^6 km

3.2.3 deep space

space at distances from the Earth of equal to, or greater than 2×10^6 km

[ITU/RR/1.177]

3.2.4 Earth Exploration-Satellite service

a radio communication service between Earth stations and one or more space stations, which may include links between space stations, in which:

- information relating to the characteristics of the Earth and its natural phenomena, including data relating to the state of the environment, is obtained from active sensors or passive sensors on Earth orbiting satellites;
- similar information is collected from airborne or ground-based platforms;
- such information may be distributed to Earth stations within the system concerned;
- platform interrogations may be included.

This service may also include feeder links necessary for its operation.

[ITU/RR/1.51]

3.2.5 frequency coordinator

manager responsible for ensuring conformity with ITU/RR

3.2.6 Meteorological-Satellite service

an Earth Exploration-Satellite service for meteorological purposes

[ITU/RR/1.52]

3.2.7 necessary bandwidth

for a given class of emission, the width of the frequency band which is just sufficient to ensure the transmission of information at a rate and with the quality required under the specified conditions

[ITU/RR/1.152]

NOTE This is taken to be equal to the occupied bandwidth.

3.2.8 occupied bandwidth

the width of a frequency band such that, below the lower and above the upper frequency limits, the mean powers emitted are each equal to 0,5 % of the total mean power of a given emission

[ITU/RR/1.153]

3.2.9 out-of-band emission

emission on a frequency or frequencies immediately outside the necessary bandwidth, which results from the modulation process, but excluding spurious emissions

[ITU/RR/1.144]

3.2.10 proximate orbits

two circular orbits whose difference in altitude is smaller than 500m and whose difference in orbital plane angle is smaller than 1,5°.

3.2.11 Space Operation service (SO)

a radio communication service concerned exclusively with the operation of spacecraft, in particular space tracking, space telemetry and space telecommand (TTC)

NOTE These functions are normally provided as part of the service in which the spacecraft is operating.

[ITU/RR/1.23]

3.2.12 Space Research service (SR)

a radio communication service in which spacecraft and other objects in space are used for scientific and technological research

[ITU/RR/1.55]

3.2.13 spurious emission

emissions on a frequency, or frequencies, which are outside $\pm 2,5$ times the occupied bandwidth and the level of which may be reduced without affecting the corresponding transmission of information

NOTE Spurious emissions include harmonic emissions, parasitic emissions, intermodulation products and frequency conversion products, but exclude out-of-band emissions.

[ITU/RR/1.145]

3.2.14 symbol rate

reciprocal of the symbol duration

NOTE See Figure 6-1.

3.2.15 unwanted emissions

consists of spurious emissions and out-of-band emissions

[ITU/RR/1.146]

3.3 Abbreviated terms

For the purpose of this Standard, the abbreviated terms from ECSS-ST-00-01 and the following apply:

Abbreviation	Meaning
@	at
2B _L	double sideband noise bandwidth
8PSK	phase shift keying of 8 states
BPSK	binary phase shift keying (see PSK)
BT _s	product of bandwidth and symbol duration
CCSDS	Consultative Committee for Space Data Systems
CLCW	command link control word
dB	decibel
dB _i	dB with respect to isotropic emission
dB _c	dB with respect to the unmodulated carrier
dBW	dB with respect to power
DRS	data relay satellite
DS	deep space
DSN	Deep Space Network of NASA
EES	Earth Exploration-Satellite service
EHF	extremely high frequency, frequency from 30 GHz to 300 GHz
EIRP	equivalent isotropically radiated power

epfd	equivalent power flux density
ESA	European Space Agency
E/S	Earth station
FIR	finite impulse response
f_N	Nyquist frequency
f_t	ranging tone frequency
GMSK	Gaussian minimum shift keying
GSO	geostationary orbit
G/T	ratio of antenna gain to system noise temperature
ITU	International Telecommunication Union
ITU-R	radio communication sector of the ITU
ITU/RR	ITU radio regulations
ksp/s	kilo symbol per second
LHC	left hand circular
LSB	least significant bit
MSB	most significant bit
Msp/s	mega symbol per second
NASA	National Aeronautics and Space Administration
NRZ	non return to zero
NRZ-L	non return to zero-level
NRZ-M	non return to zero-mark
OQPSK	offset quadrature phase shift keying
PCM	pulse code modulation
PF_D	power flux density
PLL	phase locked loop
PM	phase modulation
PSK	phase shift keying
Q-DNRZ	quaternary differential NRZ
QPSK	quadrature phase shift keying
RF	radio frequency
RFI	radio frequency interference
RHC	right hand circular
r.m.s.	root-mean-square
R_s	symbol rate
R_{chs}	channel symbol rate
R_{ES}	equivalent symbol rate
RSS	root-sum-square

Rx	receiver
S/C	spacecraft
SEF	spectral efficiency factor
SFCG	Space Frequency Co-ordination Group
SHF	super high frequency, frequency from 3 GHz to 30 GHz
SP-L	split phase-level
sps	symbol per second
SO	Space Operation service
SR	Space Research service
SRRC	square-root raised-cosine
TCM	trellis-coded modulation
TTC	telemetry, tracking and telecommand
Tx	transmitter
UHF	ultra high frequency, frequency from 300 MHz to 3 000 MHz
UQPSK	unbalanced quadrature phase shift keying

4

Frequency allocations, assignment and use

4.1 Frequency allocations to the Space Operation, Space Research and Earth Exploration-Satellite⁵ services

4.1.1 Overview

The use of frequencies by radio communication services is governed by the provisions of the Radio Regulations of the International Telecommunication Union (ITU/RR), which:

- define the various radio communication services (see clause 3.2);
- allocate frequency bands to them (see clause 4.1.2);
- lay down procedures to be followed for a frequency assignment and the frequency notification with the Radio communications Bureau of the ITU (see clause 4.3);
- specify technical conditions for the frequency use (see clause 5).

NOTE Any frequency assignment made to a particular user (spacecraft) is, as a consequence, in conformance with the ITU/RR.

4.1.2 Frequency bands allocated to the Space Radiocommunications services

4.1.2.1 Overview

Table 4-1 lists the recommended frequency bands among the available ITU bands, along with their allocated radio communication service, direction and status.

For the applicability of this Standard to the frequency bands allocated to the Meteorological-Satellite service not listed in Table 4-1, interested users can contact the responsible frequency coordinator.

⁵ Under the term Earth Exploration-Satellite service, the Meteorological Satellite service is also included.

Table 4-1: Frequency allocations to the Space Operation, Space Research and Earth Exploration-Satellite services

Frequency band (MHz) (see 4.1.2.2)	Allocated service (see 4.1.2.3)	Direction (see 4.1.2.4)	Allocation status (see 4.1.2.5)
2 025 – 2 110	SR, SO, EES	Earth-space	Primary
2 110 – 2 120	SR (DS)	Earth-space	Primary
2 200 – 2 290	SR, SO, EES	Space-Earth	Primary
2 290 – 2 300	SR (DS)	Space-Earth	Primary
7 145 – 7 190	SR (DS)	Earth-space	Primary
7 190 – 7 235	SR	Earth-space	Primary
8 025 – 8 400	EES	Space-Earth	Primary
8 400 – 8 450	SR (DS)	Space-Earth	Primary
8 450 – 8 500	SR	Space-Earth	Primary
25 500 – 27 000	SR, EES	Space-Earth	Primary
31 800 – 32 300	SR (DS)	Space-Earth	Primary
34 200 – 34 700	SR (DS)	Earth-space	Primary
37 000 – 38 000	SR	Space-Earth	Primary
40 000 – 40 500	SR	Earth-space	Primary

NOTE: To use the frequency bands given in this table, the interested users can contact the network operation manager in charge of the ground network for availability of the service at the stations of interest.

4.1.2.2 Special conditions governing the use of particular frequency bands

4.1.2.2.1 Overview

The use of certain frequency bands is governed by specific conditions that are laid down in the ITU-RR and in the Recommendations of the SFCG and CCSDS RF and Modulation Working Group (see Bibliography).

4.1.2.2.2 Evolution of the conditions

- a. The frequency coordinator shall inform applicants for frequency assignments about any evolution of the conditions stated in 4.1.2.2 that have occurred since the issue of this Standard.

NOTE See also clause 4.3.

4.1.2.3 Use of frequency bands allocated to the Space Research (deep space) service

- a. The frequency bands allocated to the Space Research (deep space) service shall only be used by category B spacecraft.

4.1.2.4 Direction indicator

- a. Frequency bands shall be used in conformance with the direction indicated in Table 4-1.

4.1.2.5 Allocation status

4.1.2.5.1 Primary allocation

- a. A service with a primary allocation status shall only share and coordinate with other co-primary services which can be allocated in the same band.
- b. A service with a primary allocation status has priority over other allocations, such as secondary and therefore it need not protect them or accept interference caused by them, or coordinate with them.

4.1.2.5.2 Secondary allocation

- a. A service with a secondary allocation status shall not cause harmful interference to any station of a primary service allocated in the same band.
- b. A service with a secondary allocation status shall not claim protection from interference caused by stations of a primary service allocated in the same frequency band.

4.2 Specific conditions for the use of certain frequency bands⁶

4.2.1 2 025 MHz – 2 120 MHz and 2 200 MHz – 2 300 MHz bands

4.2.1.1 2 025 MHz – 2 120 MHz band

4.2.1.1.1 2 025 MHz - 2 110 MHz band

- a. The EIRP transmitted from the Earth station shall be selected to allow for a margin of 3 dB on the link budget, in order to minimize interference to the Earth-space links of other spacecraft or to the space-space links from data relay satellites to user satellites, which are particularly susceptible to RFI.
- b. The use of an EIRP value higher than the one specified in 4.2.1.1.1a shall be analysed and justified.

⁶ These conditions are derived from recommendations of the SFCG (see Bibliography).

- c. Earth station transmitters shall provide the functionality for adjustable RF output power in steps of 3 dB or less.
- d. Operators shall not activate the Earth-space links during periods when no tracking and telecommand operations are performed in order to alleviate the frequency sharing situation.

NOTE Excessive Earth station EIRP not only complicates frequency co-ordination with other users, but can also prevent operations totally at some sites. As a means of RFI mitigation, if requested by priority users, ITU/RR specifies the interruption of Earth-space transmissions during the periods when they cause RFI.

4.2.1.1.2 2 110 MHz - 2 120 MHz band

- a. New assignments in the 2 110 MHz - 2 120 MHz band shall only be requested after agreement with the frequency coordinator.

NOTE The 2 110 MHz - 2 120 MHz band is part of the IMT-2000 or UMTS core band for third generation mobile telecommunication systems. Given the importance of this band for mobile telecommunications, administrations have imposed extremely severe limitations on the use of this band for Earth-space transmissions of the Space Research (deep space) service. Therefore, new assignments in this band are formally discouraged.

4.2.1.2 2 200 MHz – 2 300 MHz band

4.2.1.2.1 2 200 MHz - 2 290 MHz

- a. The maximum occupied bandwidth for spacecraft in this band shall not exceed 6 MHz.
- b. Operators shall not activate the space-to-Earth links during periods when no operational ground station is in visibility of the satellite, in order to alleviate the frequency sharing situation.
- c. The devices on spacecraft used to switch-off emissions shall have a reliability which is commensurate with the mission lifetime.

NOTE The 2 200 MHz – 2 290 MHz band is one of the most densely occupied bands allocated to the space science services with an average occupation density in excess of 25 MHz assigned per each 1 MHz allocated.

4.2.1.2.2 2 290 MHz - 2 300 MHz

There are no special requirements for this band. However, due to the constraints of the paired 2 110-2 120 MHz band given in 4.2.1.1.2 the usefulness of this band can be limited.

4.2.2 8 025 MHz – 8 400 MHz band

- a. The same RFI mitigation methods specified in 4.2.1.2.1 for the 2 200 MHz – 2 290 MHz band shall be applied to the 8 025 MHz – 8 400 MHz band.

NOTE The 8 025 MHz – 8 400 MHz band is the only direct data transmission band allocated to the Earth Exploration Satellite service below 20 GHz. Its occupation density is similar to that of the 2 200 MHz – 2 290 MHz band; additionally the interference situation is aggravated by the fact that most of the Earth Exploration-Satellites use very similar (polar) orbits.

4.2.3 8 400 MHz - 8 450 MHz band

- a. The maximum allowable bandwidth for spacecraft in this band, as a function of the symbol rate, shall not exceed the masks in Figure 4-1, where RES shall be as follows:
1. For SP-L modulation, two times the NRZ symbol rate R_s , reciprocal of the symbol duration defined in Figure 6-1 and Figure 6-2 ($R_{ES} = 2 \times R_s$).
 2. For all other cases, equal to R_s , reciprocal of the symbol duration defined in Figure 6-1 and Figure 6-2.

4.2.4 8 450 MHz – 8 500 MHz band

- a. The maximum occupied bandwidth for spacecraft in the 8 450 MHz – 8 500 MHz band shall not exceed 10 MHz.

NOTE In the use of this band, priority is given to Lagrangian point missions.

4.2.5 25,5 GHz – 27,0 GHz, 37,0 GHz – 38 GHz and 40,0 GHz – 40,5 GHz bands

- a. The bands 25,5 GHz – 27,0 GHz, 37,0 GHz – 38 GHz and 40,0 GHz – 40,5 GHz bands shall be used as agreed with the frequency coordinator.

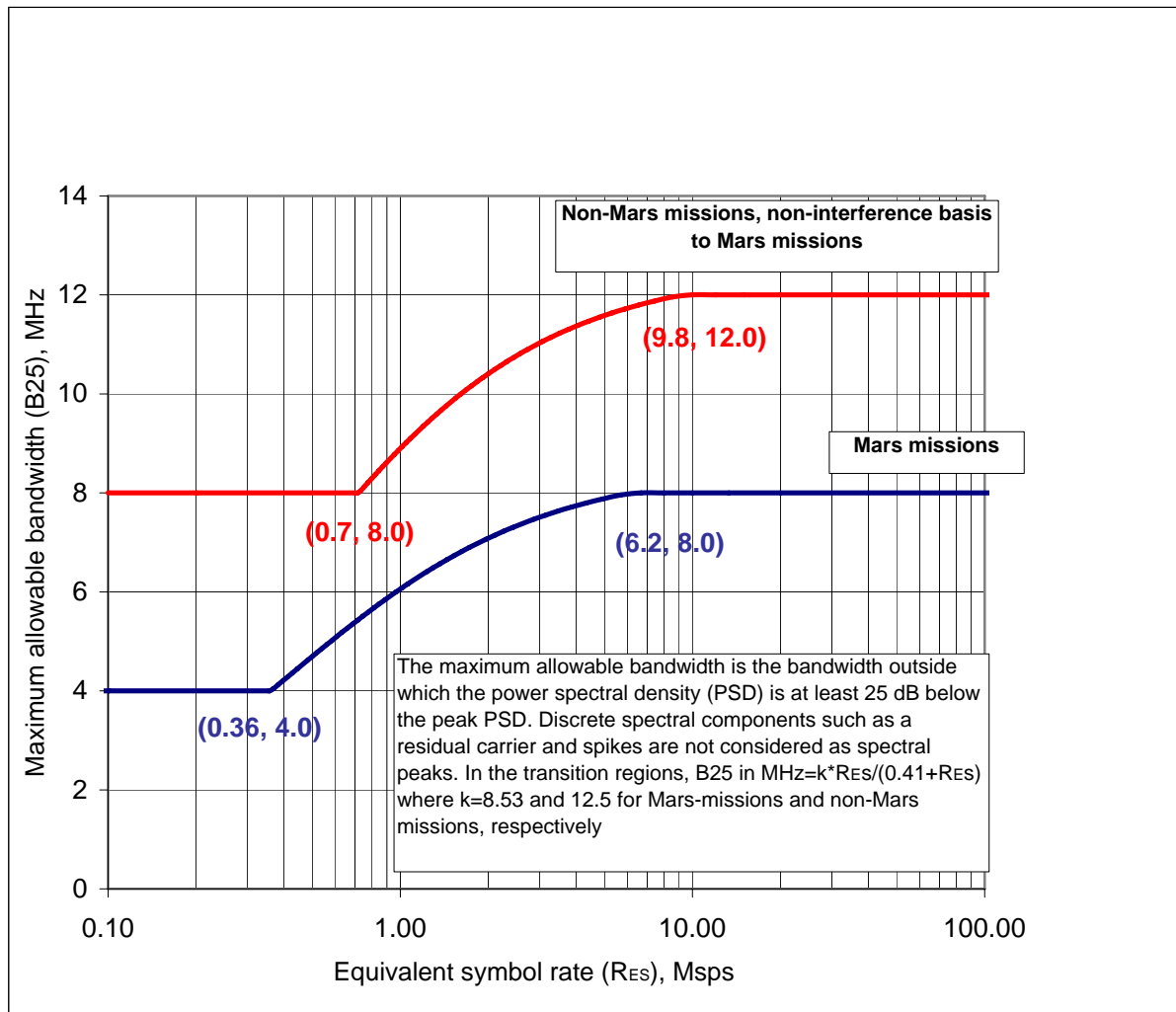

Figure 4-1: Maximum allowable bandwidth in the band 8 400 MHz - 8 450 MHz

4.3 Frequency assignment procedure

4.3.1 Choice of frequencies

- The assignment of individual frequencies in the selected band or bands shall conform to the frequency management procedure established by the frequency coordinator.
- Prior to the design phase of any spacecraft project, the project shall request the frequency assignments for the spacecraft.
- For the purpose of requirement 4.3.1.b the project shall supply to the frequency coordinator the information that conforms to his specifications.
- The information that is supplied in 4.3.1.c shall be identified if it is in a preliminary state and is to be confirmed (and finalized) at a later date.
- The entire procedure of selection of frequencies shall be carried out under the management of the frequency coordinator.

NOTE The frequency coordinator has the exclusive authority for assigning frequencies.

- f. All requests for frequency assignments or inquiries regarding frequency management matters shall be addressed to the frequency coordinator.

4.3.2 Advance publication, coordination and notification of frequencies

- a. The project manager shall provide, to the frequency coordinator, the data regarding the frequencies used by the spacecraft to enable the advance publication, coordination and notification procedures of ITU/RR/9 and ITU/RR/11 no later than three years before the planned launch date.
- b. The format established by the frequency coordinator shall be used for the purpose of 4.3.2.a.
- c. At this stage, the data supplied as per 4.3.1 shall be the final data.
- d. The procedures of ITU/RR/9 and ITU/RR/11 shall be carried out by the frequency coordinator for the satellites and Earth stations, in conformance with frequency management procedures.

5 Transmitted signals

5.1 Turnaround frequency ratio for coherent transponders⁷

5.1.1 Generation of the transmitted carrier

Transponders, flown on the spacecraft for the purpose of coherent Doppler tracking, can generate the transmitted carrier from the received carrier by means of phase-lock techniques.

5.1.2 Band pairs

- a. Band pairs should be selected from Table 5-1 together with the applicable turn-around ratio.
- b. If the turnaround ratios in Table 5-1 are not used, the ratios in Table 5-2 shall be used.

⁷ These specifications are derived from CCSDS 401.0-B-17 (see Bibliography).

Table 5-1: Turnaround frequency ratios for coherent transponder operation

	Earth-space (MHz)	Space-Earth (MHz)	Turnaround ratio (f_{up}/f_{down})	
Cat. A	2 025,833 333 – 2 108,708 333	2 200 – 2 290	221/240	
	2 025 - 2110	25 500 – 27 000	221/2772 221/2850	
	7 192,102 273 – 7 234,659 091	8 450 – 8 500	749/880	
	7 190 – 7 235	25 500 – 27 000	749/2652 749/2662 749/2678 749/2688 749/2704 749/2720 749/2736 749/2754 749/2772 749/2784 749/2800	
	Cat. B	2 110,243 056 – 2 117,746 142 ^a	2 291,666 667 – 2 299,814 815	221/240
		2 110,243 056 – 2 119,792 438 ^a	8 402,777 780 – 8 440,802 468	221/880
		7 147,286 265 – 7 177,338 735	2 290,185 185 – 2 299,814 815	749/240
		7 149,597 994 – 7 188,897 377	8 400,061 729 – 8 446,234 569	749/880
		7 147,286 265 – 7 188,897 377	31 909,913 580 – 32 095,691 358	749/3344
		7 157.689 045 – 7 188,897 377	31 803,456 798 – 31 942,123 460	749/3328
7 147. 286 265 – 7 188,897 377		32 062,592592 – 32 249,259 262	749/3360	
34 354,343 368 – 34 554,287 799		8 400,061 729 – 8 448,950 615	3599/880	
34 343,235 339 – 34 570,949 834		31 909,913 580 – 32 121,493 816	3599/3344	
34 393,221 460 – 34 570,949 834		31 803,456 798 – 31 967,802 458	3599/3328	
34 343,235 339 – 34 570,949 834	32 062,592 592 – 32 275,185 174	3599/3360		
a See clause 4.2.1.1.				

Table 5-2 Alternative turnaround frequency ratios for coherent transponder operation

	Earth-space (MHz)	Space-Earth (MHz)	Turnaround ratio (f_{up}/f_{down})
Cat. A	2 074,944 444 – 2 087,222 222	8 450 – 8 500	221/900
	7 190 – 7 235	2 255,686 275 – 2 269,803 922	765/240
Cat. B	2 110,243 056 – 2 119,792 438 ^a	31 930,555 556 – 32 075,049 383	221/3 344 ^b
	34 343,235 339 – 34 487,639 661	2 290,185 185 – 2 299,814 815	3599/240 ^b
a See clause 4.2.1.1. b Additional turnaround ratios have been developed by CCSDS for a full use of the allocated bandwidths at 32 GHz and 34 GHz.			

5.2 Carrier frequency stability⁸

5.2.1 Spacecraft transmitter

- a. The frequency stability of the transmitted RF carriers shall be within the limits specified in Table 5-3.

Table 5-3: Frequency stability for spacecraft transmitters

Frequency band (MHz)	Maximum frequency instability
2 200 – 2 290 8 450 – 8 500	$\pm 2 \times 10^{-5}$ under all conditions and for the lifetime of the spacecraft.
8 025 – 8 400 25 500 – 27 000	$\pm 2 \times 10^{-5}$ under all conditions and for the lifetime of the spacecraft.
2 290 – 2 300 8 400 – 8 450 31 800 – 32 300	$\pm 2 \times 10^{-5}$ under all conditions and for the lifetime of the spacecraft. $\pm 1,5 \times 10^{-6}$ at any one temperature of transmitter in the range +10 °C to +40 °C in any 15 h following 4 h of warm-up. $\pm 0,2 \times 10^{-6}/^{\circ}\text{C}$ within the transmitter temperature range +10 °C to +40 °C. Aging $\pm 2,5 \times 10^{-6}$ per year.

- b. In addition to clause 5.2.1.a for Category B missions the short term frequency stability shall be such that the resulting phase error when tracking the carrier with a second-order PLL with loop bandwidth $2B_L$ as

⁸ These specifications are derived from CCSDS 401.0-B-17 (see Bibliography).

specified for the mission, does not exceed 10 degrees peak in high signal-to-noise conditions and in non-coherent mode.

NOTE 1 The “short term frequency stability” includes phase noise contribution and any “instantaneous” phase or frequency variations (“discontinuities”) due to technological aspects and related to oscillator implementation.

NOTE 2 Depending on the link budget and on the ground station $2B_L$ value, this requirement may have strong impact on the onboard subsystem architecture and the selection of the proper oscillator technology.

5.2.2 Spacecraft receiver

- a. The frequency stability of spacecraft receivers shall be within the limits specified in Table 5-4.

NOTE For phase lock loop receivers the frequency referred to is the best lock frequency.

Table 5-4: Frequency stability for spacecraft receivers

Frequency band (MHz)	Maximum frequency instability
2 025 – 2 110 7 190 – 7 235	$\pm 2 \times 10^{-5}$ under all conditions including $\pm 4,8 \times 10^{-6}$ initial setting error. Aging over seven years $\pm 7,1 \times 10^{-6}$.
2 110 – 2 120 7 145 – 7 190 34 200-34 700	<p>$\pm 2 \times 10^{-5}$ under all conditions including $\pm 4,8 \times 10^{-6}$ initial setting error.</p> <p>$\pm 1,7 \times 10^{-5}$ at any one temperature in the range $+10\text{ }^\circ\text{C}$ to $+40\text{ }^\circ\text{C}$ in any 15 h after a warm-up period of 4 h.</p> <p>$\pm 2,4 \times 10^{-7}/^\circ\text{C}$ over the temperature range $+10\text{ }^\circ\text{C}$ to $+40\text{ }^\circ\text{C}$.</p> <p>Aging $\pm 2,5 \times 10^{-6}$ per year.</p>

5.2.3 Ground station equipment

- a. The RF carriers transmitted by the Earth station shall be phase locked to a reference frequency standard having an accuracy of at least $\pm 5 \times 10^{-9}$ under all conditions.

NOTE Stability requirements on ranging and Doppler tracking can be found in ECSS-E-ST-50-02.

5.3 Polarization⁹

- a. Earth-space and space-Earth links shall be circularly polarized.

NOTE For a right-hand circularly-polarized wave, the sense of polarization determined by the electric field vector rotates with time in a right-hand or clockwise direction when observed in any fixed plane, normal to the direction of propagation, whilst looking in the direction of propagation.

- b. Earth stations shall be capable of transmitting right-hand or left-hand circular polarization upon discretion of the user.

NOTE 1 For practical reasons, spacecraft generally use the same sense of polarization for the Earth-space link and the space-Earth link.

NOTE 2 Most Earth stations have the capability of combining two orthogonal circular polarizations on the space-Earth link.

5.4 Occupied bandwidth considerations¹⁰

- a. The occupied bandwidth shall not be wider than the maximum values given in Table 5-5, where f_i is the ranging tone frequency and R_s the symbol rate, reciprocal of the symbol duration defined in Figure 6-1 and Figure 6-2.

NOTE 1 There are no requirements for occupied bandwidths for the 25,5-27,0 GHz, 31,8-32,3 GHz, 34,2-34,7 GHz, 37,0-38,0 GHz and 40,0-40,5 GHz bands at the time of publication of this Standard. Users interested in the use of these bands can contact the frequency coordinator for advice.

NOTE 2 The values given in Table 5-5 represent the maximum values, however it is specified in ITU/RR/3.9 that all efforts are made to restrict the occupied bandwidth.

⁹ These specifications are derived from CCSDS 401.0-B-17 (see Bibliography).

¹⁰ These specifications are derived from recommendations of the SFCG (see Bibliography).

Table 5-5: Occupied bandwidth

Frequency band (MHz)	Function	Category	Maximum occupied bandwidth
2 025 – 2 120 and 7 145 – 7 235	Telecommand (8 kHz subcarrier)	A & B	50 kHz
	Telecommand (16 kHz subcarrier)	A & B	100 kHz
	Telecommand (direct modulation)	A & B	$12 \times R_s$
	Ranging	A & B	$2,5 \times f_t^c$
2 200 – 2 290 and 8 450 – 8 500	Telemetry ^a ($R_s < 10$ ksps)	A	300 kHz
	Telemetry ^a (10 ksps $\leq R_s \leq 60$ ksps)	A	1 200 kHz or $30 \times R_s$, whichever is smaller
	Telemetry (60 ksps $< R_s < 2$ Msps)	A	1 200 kHz or $12 \times R_s$, whichever is larger, up to 6 MHz at 2 GHz and 10 MHz at 8 GHz
	Telemetry ($R_s \geq 2$ Msps)	A	$1,1 \times R_s$, up to 6 MHz at 2 GHz and 10 MHz at 8 GHz
	Ranging	A	$2,5 \times f_t$
2 290 – 2 300	Telemetry ($R_s \geq 2$ Msps)	B	$1,2 \times R_s^b$
8 025 – 8 400	Telemetry	-	$1,1 \times R_s$
2 290 – 2 300 and 8 400 – 8 450	Ranging	B	$2,5 \times f_t$
8400 – 8 450	Telemetry ($R_s < 2$ Msps)	B	Shall meet requirements of Figure 4-1 for maximum allowable bandwidth
	Telemetry ($R_s \geq 2$ Msps)	B	$1,2 \times R_s$, and shall meet requirements of Figure 4-1 for maximum allowable bandwidth

a For missions with several data rates, the maximum occupied bandwidth for the highest data rate may also be applied to the lower rates.

b There are no special requirement for symbol rates less than 2 Msps.

c This value can be exceeded by deep space missions for certain conditions subject to approval by the frequency coordinator.

5.5 Emissions¹¹

5.5.1 Unwanted emission power level

5.5.1.1 Transmitter spurious emissions and harmonics

- a. The spurious emissions, including harmonics, generated by spacecraft and Earth station transmitters shall not exceed the levels given in Table 5-6.

NOTE This is consistent with ITU/RR/AP3.

Table 5-6: Maximum level of spurious emissions

Carrier frequency ^a (MHz)	Case	Maximum spurious level
100 – 40 500	Modulated and unmodulated transmissions ^b	-60 dBc, measured in a reference bandwidth of 4 kHz
	Carrier harmonics of category B spacecraft transmitters	-30 dBc
<p>a The frequency range to be used for verification of this requirement is defined in recommendation ITU-R SM.329.</p> <p>b Although ITU/RR/AP3, Table II (WRC-03), Footnote 17, in principle, exempts deep space missions from limits on spurious emissions, the maximum value given in this Table is applicable for all these missions since they may travel frequently for long periods of time below the 2 000 000 km limit of deep space.</p>		

5.5.1.2 Protection of radio astronomy bands

- a. Radio astronomy measurements performed as spectral line observations using narrow bandwidths and as continuum observations using wide bandwidths shall be protected from satellite unwanted emissions.

NOTE This is consistent with Recommendation ITU-R RA.769-2.

- b. Unwanted emissions of a GSO satellite falling into the frequency bands of Radio Astronomy shall be kept to power flux density values 15 dB less than the limits given in Table 5-7 and Table 5-8, which apply to terrestrial sources of interference.

NOTE The 15 dB reduction of the Radio astronomy 0 dBi-gain protection levels from terrestrial sources is required by Recommendation ITU-R RA.769-2 for the GSO satellite emissions in the Radio astronomy frequency bands.

¹¹ These requirements are extracted from ITU/RR.

- c. Unwanted emissions of a non-GSO satellite falling into the frequency bands of Radio Astronomy shall be kept to a power flux density values less than the limits given in Table 5-7 and Table 5-8 (which apply to terrestrial sources of interference) by the following values:
1. For a single satellite: 13 dB.
 2. For a networks composed of more than one satellite: a value obtained from the frequency coordinator.

NOTE 1 The power flux density limits shown in Table 5-7 and Table 5-8 apply directly to terrestrial sources of emissions, assuming they are received through a 0 dBi radio telescope antenna side lobe. For satellite emissions, the radio telescope antenna gain is taken into account in the evaluation of the limit.

NOTE 2 For the non-GSO case, Recommendation ITU-R RA 1513-1 establishes that an individual satellite can exceed the radioastronomy protection levels for up to 2 % of the observation time and Recommendation ITU-R M.1583 provides a rather complex mechanism to calculate the corresponding equivalent pfd (epfd) limit. The simpler alternative method provided here is based on the fact that the 2 % observation time limit can be translated into an equivalent sky blockage of 2 % of the hemisphere visible from the radiotelescope. The 13-dB value is obtained by entering half of the solid angle corresponding to 2 % of the visible hemisphere (equivalent to an antenna offset of $5,74^\circ$ for a single satellite) into the reference radioastronomy antenna pattern ($32-25 \log \varphi$).

Table 5-7: Threshold levels of interference detrimental to radio astronomy spectral line (i.e. narrow bandwidth) observations at the surface of the Earth due to terrestrial interference sources (Recommendation ITU-R RA.769-2)

Centre frequency (MHz)	Assumed observation bandwidth of spectral line (kHz)	Power flux density over the observation bandwidth (dBW/m²)
327	10	-204
1 420	20	-196
1 612	20	-194
1 665	20	-194
4 830	50	-183
14 488	150	-169
22 200	250	-162
23 700	250	-161
43 000	500	-153
48 000	500	-152
88 600	1 000	-148
150 000	1 000	-144
220 000	1 000	-139
265 000	1 000	-137

Table 5-8: Threshold levels of interference detrimental to radio astronomy continuum (i.e. wide bandwidth) observations at the surface of the Earth due to terrestrial interference sources (Recommendation ITU-R RA.769-2)

Centre frequency (MHz)	Assumed observation bandwidth (MHz)	Power flux density over the observation bandwidth (dBW/m ²)
13,385	0,05	-201
25,610	0,12	-199
73,8	1,6	-196
151,525	2,95	-194
325,3	6,6	-189
408,05	3,9	-189
611	6,0	-185
1 413,5	27	-180
1 665	10	-181
2 695	10	-177
4 995	10	-171
10 650	100	-160
15 375	50	-156
22 355	290	-146
23 800	400	-147
31 550	500	-141
43 000	1 000	-137
89 000	8 000	-129
150 000	8 000	-124
224 000	8 000	-119
270 000	8 000	-117

5.5.1.3 Protection of Space Research (deep space) bands

- a. Unwanted emissions falling into the frequency bands of Space Research (deep space) should be kept to power flux spectral density values less than those given in Table 5-9 at the deep space antenna sites.

NOTE From Recommendation ITU-R SA.1157-1 and SFCG Recommendation 14-1R1.

- b. Whenever the limits of Table 5-9 are not met, coordination shall be initiated between the offending satellite and the Space Research (deep space) users, via the frequency coordinator.

NOTE This is consistent with SFCG Recommendation 14-1R1 and SFCG Administrative Resolution A12-1.

Table 5-9: Harmful interference levels at deep space antenna sites

Frequency band	Power flux spectral density at antenna location (dBW/m ² /Hz)
2 290 MHz – 2 300 MHz	-257,0
8 400 MHz – 8 450 MHz	-255,1
31,8 GHz – 32,3 GHz	-249,3
37,0 GHz – 38,0 GHz	-251,0

5.5.1.4 Protection of launcher RF systems

- a. Spurious emissions from spacecraft which are active during the launch shall be in conformance to the RF interface requirements of the launcher.

NOTE For guidance on the levels to be met by the spacecraft equipment in terms of directly measurable parameters (e.g. power, frequency in an antenna feed cable), the conversion method given in Annex C can be used. This annex also provides some examples of typical requirements for Ariane 5. Note that the conversion method given is used to derive an estimate of the values; however, the real requirement is on the actual field strength at the vehicle equipment bay antennas.

5.5.2 Cessation of emissions

- a. Each spacecraft shall be fitted with devices to ensure the immediate cessation of its radio emissions by telecommand whenever such a cessation is requested.

NOTE This is consistent with ITU/RR/22.1.

- b. Since the temporary cessation of emissions is an efficient means of RFI mitigation in densely occupied bands, the reliability of the devices used for the switch-off of emissions shall be commensurate with the mission lifetime.

NOTE See SFCG Recommendation 12-4R3.

5.5.3 Power flux density limits at the Earth's surface

- a. The power flux density (PFD) at the Earth's surface produced by emissions from a spacecraft, for all conditions and all methods of modulation, shall not exceed the values given in Table 5-10.

NOTE 1 See ITU/RR/21.16.

NOTE 2 In all cases, the limits relate to the PFD, which are obtained under assumed free-space propagation conditions.

- b. The PFD limits shall be applied during all mission phases.

NOTE This can involve means for reducing EIRP onboard the spacecraft.

Table 5-10: Power flux density limits at the Earth's surface

Frequency (MHz)	Angle of incidence (δ) above horizontal plane (degrees)	Power flux density (dBW/m ² /4 kHz)
1 525 – 2 300	0 – 5	-154
	5 – 25	$-154 + 0,5 \times (\delta - 5)$
	25 – 90	-144
8 025 – 8 500	0 – 5	-150
	5 – 25	$-150 + 0,5 \times (\delta - 5)$
	25 – 90	-140
Frequency (MHz)	Angle of incidence (δ) above horizontal plane (degrees)	Power flux density (dBW/m ² /1 MHz)
25 500 – 27 000	0 – 5	-115
	5 – 25	$-115 + 0,5 \times (\delta - 5)$
	25 – 90	-105
31 800 – 32 300	0 – 5	-120
	5 – 25	$-120 + 0,75 \times (\delta - 5)$
	25 – 90	-105
37 000 – 38 000 (non-GSO satellites)	0 – 5	-120
	5 – 25	$-120 + 0,75 \times (\delta - 5)$
	25 – 90	-105
37 000 – 38 000 (GSO satellites)	0 – 5	-125
	5 – 25	$-125 + (\delta - 5)$
	25 – 90	-105

5.5.4 Power flux density limits at the GSO in the 25,5 GHz - 27,0 GHz band¹²

- a. Satellites in Sun-synchronous orbit or in an orbit that is proximate to the orbits of the DRS user satellites shall not produce a power-flux-density

¹² See Recommendation ITU-R SA.1625.

greater than $-155 \text{ dB(W/m}^2\text{)}$ in 1 MHz at any location on the geostationary orbit (GSO) for more than 0,1 % of the time.

- b. Satellites in orbits other than that specified in 5.5.4a shall not produce a power-flux-density greater than $-155 \text{ dB(W/m}^2\text{)}$ in 1 MHz at any location on the GSO for more than 1 % of the time.

5.5.5 Power limits for Earth station emissions¹³

5.5.5.1 Frequency bands between 1 GHz and 15 GHz

- a. Except for the Space Research service (deep space), the equivalent isotropically radiated power (EIRP transmitted in any direction towards the horizon by an Earth station operating in the frequency bands between 1 GHz and 15 GHz shall not exceed the following (where θ is the angle of elevation of the horizon viewed from the centre of radiation of the antenna of the Earth station and measured in degrees as positive above the horizontal plane and as negative below it):
 - 1. $+40 \text{ dBW}$ in any 4 kHz band for $\theta \leq 0^\circ$;
 - 2. $(+40 + 3 \times \theta) \text{ dBW}$ in any 4 kHz band for $0^\circ \leq \theta \leq 5^\circ$.
- b. For the Space Research service (deep space), the EIRP towards the horizon for an Earth station shall not exceed $+55 \text{ dBW}$ in any 4 kHz band, regardless of the horizon elevation.

NOTE For angles of elevation of the horizon greater than 5° , there is no restriction on the EIRP transmitted by an Earth station towards the horizon.

5.5.5.2 Frequency bands above 15 GHz

- a. Except for the Space Research service (deep space), the EIRP transmitted in any direction towards the horizon by an Earth station operating in the frequency bands above 15 GHz shall not exceed the following (where θ is the angle of elevation of the horizon viewed from the centre of radiation of the antenna of the Earth station and measured in degrees as positive above the horizontal plane and as negative below it):
 - 1. $+64 \text{ dBW}$ in any 1 MHz band for $\theta \leq 0^\circ$;
 - 2. $(+64 + 3 \times \theta) \text{ dBW}$ in any 1 MHz band for $0^\circ \leq \theta \leq 5^\circ$.
- b. For the Space Research service (deep space), the EIRP towards the horizon for an Earth station shall not exceed $+79 \text{ dBW}$ in any 1 MHz band, regardless of the horizon elevation.

NOTE For angles of elevation of the horizon greater than 5° , there is no restriction for the EIRP transmitted by an Earth station towards the horizon.

¹³ See ITU Radio Regulations (clause 2).

5.5.5.3 Limits to elevation angles

- a. No transmission shall be affected by Earth station antennas at elevation angles of less than the following (where the elevation angles are measured from the horizontal plane to the direction of maximum radiation, i.e. antenna main beam direction):
 1. 3° for the Space Operation and the Earth Exploration-Satellite services.
 2. 5° for the Space Research service, Category A.
 3. 10° for the Space Research service, Category B.
- b. Since host administrations for Earth stations may specify tighter minimum elevation limits, the minimum elevation angle for transmission shall be agreed with the frequency coordinator.

5.5.6 Time limitations on transmissions

- a. Transmissions from Earth stations to spacecraft shall be limited in time to the periods during which actual Earth-space link telecommunications or tracking operations are carried out.
 - NOTE 1 See also 4.2.
 - NOTE 2 Example of Earth-space link telecommunications is telecommand.
- b. Spacecraft telecommunication system designs shall not rely only on the presence of a continuous Earth-space carrier in the absence of telecommand or tracking operations.
- c. Spacecraft shall limit their transmission of RF power towards the Earth to the periods when telecommunications or tracking operations are carried out.
 - NOTE 1 See also 4.2.
 - NOTE 2 Example of space-Earth link telecommunication is reception of telemetry and data.

6

Modulation

6.1 Phase modulation with residual carriers

6.1.1 Application

- a. Phase modulation shall be used for the following:
 1. Telemetry in the UHF (2 200 MHz – 2 300 MHz), SHF (8 400 MHz – 8 500 MHz) and EHF (31,8 GHz – 32,3 GHz) bands, unless modulation in accordance with clause 6.2 of this Standard is adopted.
 2. Telecommand in the UHF (2 025 MHz – 2 120 MHz), SHF (7 145 MHz – 7 235 MHz) and EHF (34,2 GHz – 34,7 GHz) bands.
 3. Ranging (Earth–space) in the UHF (2 025 MHz – 2 120 MHz), SHF (7 145 MHz – 7 235 MHz) and EHF (34,2 GHz – 34,7 GHz) bands.
 4. Ranging (space–Earth) in the UHF (2 200 MHz – 2 300 MHz), SHF (8 400 – 8 500 MHz) and EHF (31,8 GHz – 32,3 GHz) bands.

6.1.2 Modulating waveforms

- a. The following modulating waveforms may be used:
 1. Telemetry, a subcarrier modulated by PCM data.
 2. Telemetry, PCM data, SP–L encoded.
 3. Telecommand, a subcarrier modulated by PCM data.
 4. Telecommand, PCM data, SP–L encoded.
 5. Ranging, the appropriate ranging baseband signal.

NOTE 1 In the case of simultaneous telecommand, ranging and telemetry, when selecting telecommand and telemetry modulation schemes it is important to take into account their mutual interference.

NOTE 2 See also ECSS-E-ST-50-02.

6.1.3 PCM waveforms and data rates

a. PCM data signals shall be limited to the waveforms and symbol rates given in Table 6-1 as follows.

1. For the RF carrier bands of 2 025 MHz – 2 120 MHz, 7 145 MHz – 7 235 MHz, and 34 200 MHz – 34 700 MHz (telecommand):

(a) Use of NRZ–M for category B is prevented.

(b) Use of 4 ksps only with 16 kHz subcarrier.

NOTE Requirement 6.1.3a.1(a) is a restriction of CCSDS recommendation 401 (2.2.3) but is justified by the better performance of NRZ-L for Category B missions.

2. For the RF carrier bands of 2 200 MHz - 2 300 MHz, 8 400 MHz - 8 500 MHz and 31 800 MHz - 32 300 MHz (telemetry), SP-L is prevented for symbol rates below 10 ksps.

NOTE For the definition of the PCM waveforms and symbol duration, refer to Figure 6-1 and Figure 6-2.

Table 6-1: PCM waveforms and rates for residual carrier modulation

RF carrier (MHz)	Function	Symbol rate (sps)	PCM waveform	Special limitations
2 025 – 2 120 7 145 – 7 235 34 200 – 34 700	Telecommand	$4\,000/2^n$ $n = 0,1..9$	NRZ–L NRZ–M	1) See 6.1.3a.1(a) 2) See 6.1.3a.1(b)
		$4\,000 \times 2^n$ $n = 1 .. 6^c$	SP–L	
2 200 – 2 300 8 400 – 8 500 31 800 – 32 300	Telemetry ^{a b}	$10^2 - 10^6$	NRZ–L SP–L	1) See 6.1.3a.2 2) See 6.1.4.1.3a
<p>a Symbol rates below 100 sps can be supported on a case by case basis. Users interested in such support, can contact the network operation manager in charge of the ground network of interest.</p> <p>b The range of symbol rates is indicative only. For the rate used, the provisions in Table 5-5 and Table 6-2 apply.</p> <p>c The implementation of this capability can be still incomplete. Users interested in such support, should contact the network operation manager in charge of the ground network of interest.</p>				

b. For all data signals producing a square wave baseband PCM waveform, the symbol asymmetry measured at 50 % of the peak-to-peak amplitude point shall not exceed 1 % with the symbol asymmetry defined as follows:

$$\text{Symbol Asymmetry} = \frac{| \text{long symbol} - \text{short symbol} |}{\text{long symbol} + \text{short symbol}}$$

where long and short symbol refers to the duration of the long and short symbols

- c. SP-L shall not be used except for direct modulation of the RF carrier and therefore without subcarrier.
- d. NRZ waveforms shall only be used when modulated onto a subcarrier.

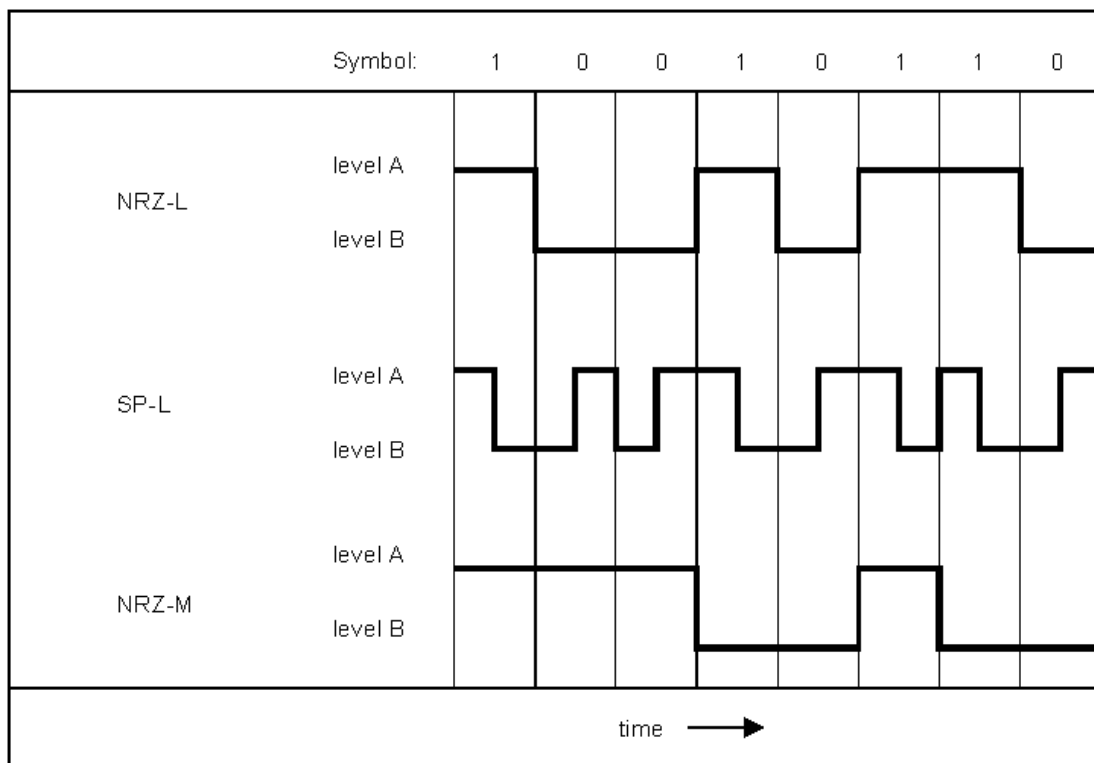

- NRZ-L level A signifies symbol "1"
level B signifies symbol "0"
- SP-L¹⁴ level A during the first half-symbol followed by
level B during the second half-symbol signifies symbol "1"
level B during the first half-symbol followed by
level A during the second half-symbol signifies symbol "0"
- NRZ-M level change from A to B or B to A signifies symbol "1"
no change in level signifies symbol "0"

Figure 6-1: PCM waveforms and symbol duration definition

¹⁴ SP-L is also known in literature as bi-phase modulation or Manchester encoding.

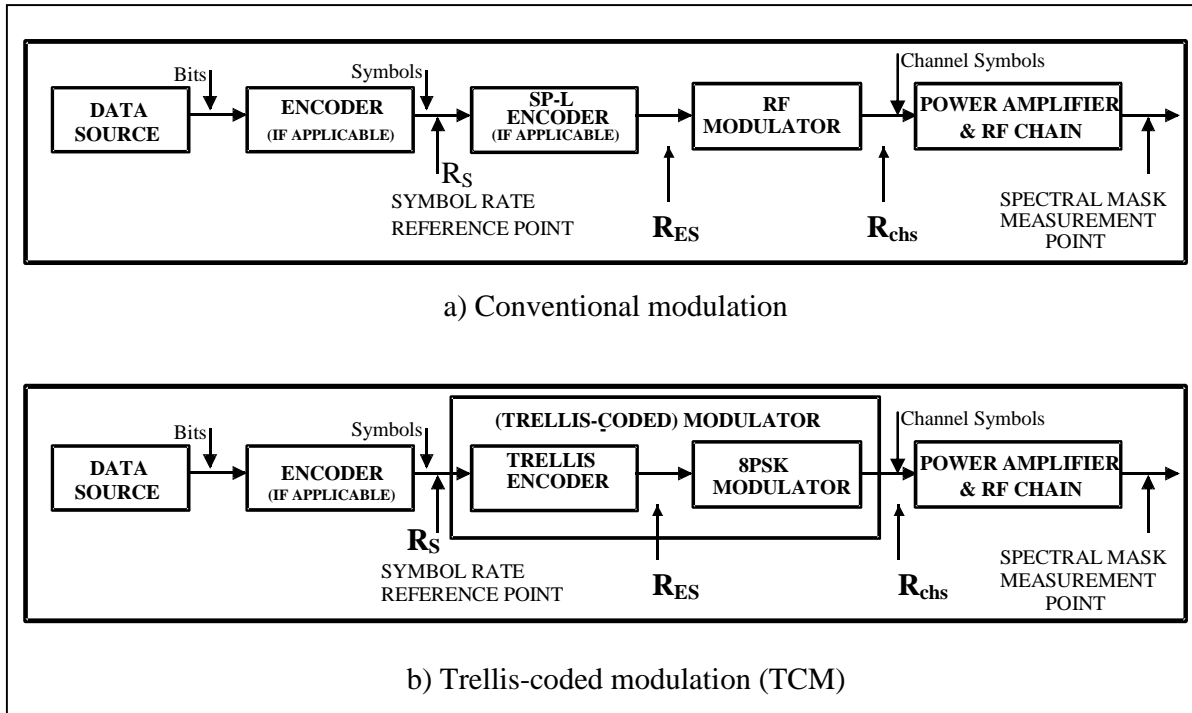

Figure 6-2: Symbol rate reference point

6.1.4 Use of subcarriers

6.1.4.1 Subcarriers

6.1.4.1.1 General

- a. The subcarriers and modulating waveforms listed in Table 6-2 shall be used.

Table 6-2: Subcarriers used with phase-modulated carriers

RF Carrier (MHz)	Function	Subcarrier (kHz)	Modulation waveform	Subcarrier waveform	References
2 025 – 2 110 7 190 – 7 235	Telecommand (Category A)	8 or 16	NRZ-L NRZ-M	sine	See 6.1.4.1.2
2 110 – 2 120 7 145 – 7 190 34 200 – 34 700	Telecommand (Category B)	8 or 16	NRZ-L ^a	sine	See 6.1.4.1.2
2 200 – 2 290 8 450 – 8 500	Telemetry (Category A)	2 – 300	NRZ-L	sine	See 6.1.4.1.3
2 290 – 2 300 8 400 – 8 450 31 800 – 32 300	Telemetry (Category B)	2 – 300	NRZ-L	square	See 6.1.4.1.3

^a This choice is a restriction of CCSDS recommendation 401 (2.2.3) but is justified by the better performance of NRZ-L for Category B missions.

6.1.4.1.2 Telecommand

- a. For telecommand transmission using a subcarrier, only two subcarrier frequencies shall be used.
- b. In the case specified in 6.1.4.1.2a when the 4 ksps symbol rate is used, the subcarrier shall be 16 kHz.
- c. For telecommand symbol rates in excess of 4 ksps, the symbols shall be SP-L encoded and directly modulated onto the carrier.

6.1.4.1.3 Telemetry

- a. For NRZ telemetry symbol rates above 60 ksps, subcarriers shall not be used and one of the following modulation schemes shall be used:
 - SP-L encoded symbols and direct modulation on the carrier for symbol rates as high as 1 Msps in the 2 200 MHz – 2 300 MHz and 8 400 MHz – 8 500 MHz bands.
 - Modulation in conformance to clause 6.2 of this Standard.
- b. For telemetry subcarrier frequencies above 60 kHz, a subcarrier frequency-to-highest symbol rate ratio not exceeding 4 (for category A missions) or 5 (for category B missions) should be used, with a maximum subcarrier frequency of 300 kHz.
- c. In case a ratio of 4 or 5 leads to spectral overlap with other signal components, the subcarrier frequency-to-highest symbol rate ratio shall be the smallest integer achieving less than 0,3 dB degradation (category A) or less than 0,1 dB degradation (category B) in the symbol detection process due to the other signal interference.
- d. For missions with multiple symbol rates, the subcarrier frequency used for the highest symbol rate may be also used for the lower symbol rates.
- e. Telemetry subcarrier frequencies shall conform to the following requirements:
 1. carrier acquisition by the ground receivers, as specified in clause 7.1;
 2. occupied bandwidth, as specified in clause 5.4;
 3. compatibility between ranging and telemetry.

NOTE For compatibility between ranging and telemetry, see ECSS-E-ST-50-02.

6.1.4.2 Subcarrier frequency stability

6.1.4.2.1 Telecommand subcarriers

- a. The telecommand subcarrier shall have a frequency within $\pm 1 \times 10^{-5}$ of its nominal value.
- b. The frequency stability shall be, as a minimum:
 1. $\pm 5 \times 10^{-6}$ over 24 h;
 2. $\pm 1 \times 10^{-6}/s$.

- c. For SP-L modulation, the stability requirements of 6.1.4.2.1a and 6.1.4.2.1b shall apply to the symbol rate.

6.1.4.2.2 Telemetry subcarriers

- a. The telemetry subcarrier shall have a frequency within $\pm 1 \times 10^{-4}$ of its nominal value at all times.
- b. The frequency variation due to power-supply voltage, temperature and other spacecraft influences shall be less than $\pm 1 \times 10^{-5}$ over any 5 minutes period.
- c. The short-term frequency stability shall be a minimum of $\pm 1 \times 10^{-6}$, over any time period less than or equal to 100 times the subcarrier's waveform period.
- d. For SP-L modulation, the stability requirements of 6.1.4.2.2a, 6.1.4.2.2b and 6.1.4.2.2c shall apply to the symbol rate.

6.1.4.2.3 Subcarrier modulation

- a. Modulation of subcarriers used for telemetry and telecommand shall be PSK.
- b. The subcarrier frequency shall be an integer multiple of the symbol rate.
- c. At each transition in the PCM waveform, the subcarrier shall be reversed in phase.
- d. The transitions in the PCM waveform shall coincide with a subcarrier zero crossing to within $\pm 2,5$ % of a subcarrier period.
- e. At all times, for more than 25 % of a subcarrier period after a phase reversal, the phase of the modulated subcarrier shall be within $\pm 5^\circ$ of that of a perfect PSK signal.
- f. For NRZ waveforms, the beginning of the symbol intervals shall coincide with the following:
 - 1. For NRZ-M waveforms: with a subcarrier zero crossing;
 - 2. For NRZ-L waveforms: with a positive-going subcarrier zero crossing for symbols "1" and with a negative-going zero crossing for symbols "0".

6.1.5 Data transition density

- a. To ensure recovery of the symbol clock by the ground demodulators, the transition density in the transmitted PCM waveform shall not be less than the following values:
 - 1. 125 in any sequence of 1 000 consecutive symbols for category A;
 - 2. 275 in any sequence of 1 000 consecutive symbols for category B.
- b. To ensure recovery of the symbol clock by the ground demodulators, the maximum string of either ones or zeros shall be limited to 64 symbols.
- c. When the specifications in 6.1.5a and 6.1.5b are not ensured for the channel by other methods, a pseudo-randomizer in conformance with ECSS-E-ST-50-01 clause 9 shall be used.

6.1.6 Carrier modulation index

- a. The peak modulation index shall be between the minima and the maxima stated in Table 6-3.
- b. When two or more channels are transmitted simultaneously on the Earth-space link, the combined peak modulation index (resulting from the linear sum of the peak indexes) should not exceed 1,75 rad.
- c. When the specifications in 6.1.6b are not met, the combined peak modulation index shall be such that the resulting carrier suppression conforms to 6.1.11a.
- d. Worst case tolerances shall be used to meet clause 6.1.6.

Table 6-3: Limits of the peak modulation index

Function	Min. (radians peak)	Max. (radians peak)
Telecommand (NRZ-L, NRZ-M)	0,2	1,4
Telecommand (SP-L)	0,2	1,0
Telemetry (sinewave subcarrier)		1,5
Telemetry (squarewave subcarrier or SP-L)		1,25 ^a
Ranging Earth-space	0,1	1,4
Ranging space-Earth	0,01 ^b	0,7
<p>a A maximum of 1,39 rad can be used provided that the carrier tracking loop's signal-to-noise ratio remains above 15 dB.</p> <p>b Effective ranging modulation index considering the power sharing due to remodulated uplink noise.</p>		

6.1.7 Sense of modulation

- a. A positive-going video signal shall result in an advance of the phase of the radio frequency carrier.
- b. For directly modulated SP-L waveforms a symbol "1" shall result in an advance of the phase of the radio frequency carrier at the beginning of the symbol interval, and a symbol "0" in a delay.

6.1.8 Modulation linearity

- a. The phase deviation, as a function of the video voltage applied to the modulator, shall not deviate from the ideal linear response by more than ± 3 % of the instantaneous value for deviations up to 1,5 rad peak.

6.1.9 Residual amplitude modulation

- a. Residual amplitude modulation of the phase modulated RF signal shall be less than 2 %.

6.1.10 Carrier phase noise

- a. The phase noise of the unmodulated carrier shall be measured in non-coherent mode.
- b. Phase noise of the unmodulated carrier, integrated between 10 Hz and 100 kHz, shall be less than the following values:
 1. 2° r.m.s. at UHF (2 025 MHz – 2 110 MHz and 2 200 MHz – 2 290 MHz).
 2. 4° r.m.s. at SHF (7 190 MHz – 7 235 MHz, and 8 450 MHz – 8 500 MHz).
- c. Phase noise of the unmodulated carrier, integrated between 0,1 Hz and 1 kHz, shall be less than 1° r.m.s. at UHF (2 110 MHz – 2 120 MHz and 2 290 MHz – 2 300 MHz).
- d. Phase noise of the unmodulated carrier, integrated between 1 Hz and 10 kHz, shall be less than the following values:
 1. 4° r.m.s. at SHF (7 145 MHz – 7 190 MHz, and 8 400 MHz – 8 450 MHz).
 2. 10° r.m.s. at EHF (31,8 GHz - 32,3 GHz and 34,2 GHz - 34,7 GHz).
- e. If specifications 6.1.10b, 6.1.10c and 6.1.10d are not met over the indicated integration ranges, integration shall be carried out taking into account the mission selected loop bandwidths and symbol rates.

6.1.11 Residual carrier, out-of-band emission and discrete spectral lines¹⁵

- a. The residual power in the modulated carrier shall be greater than -15 dBc for space-Earth and -10 dBc for Earth-space links.
- b. Discrete lines in the unmodulated transmitted RF signal spectrum, caused by baseband or RF bandwidth limitations, non-linearity of the channel, digital implementation of the frequency synthesis, or any other effects shall be less than -45 dBc inside the occupied bandwidth.
- c. Modulation shall not result in the introduction of lines with power greater than -30 dBc in the occupied bandwidth.
- d. Modulation shall not result in the introduction of discrete spectral lines greater than -30 dBc in the following frequency ranges around the carrier:
 1. ± 60 kHz for UHF (2 200 MHz – 2 300 MHz);
 2. ± 220 kHz for SHF (8 400 MHz – 8 500 MHz);
 3. ± 850 kHz for EHF (31,8 GHz – 32,3 GHz).
- e. For the case of filtered SP-L modulation, the spectral lines at the even multiples of the symbol rate shall not be higher than -20 dBc.
- f. The out-of-band emission due to the modulation shall comply with the spectral roll-off of clause 6.3.

¹⁵ Additional limitations on the telemetry modulation spectrum can be specified by the project manager to ensure the cleanliness of the ranging signals when simultaneous ranging and telemetry are used.

6.2 Suppressed carrier modulation^{16, 17}

6.2.1 Application and modulation schemes¹⁸

- a. Modulation with suppressed carrier shall be used rather than residual carrier phase modulation for telemetry in the UHF (2 200 MHz – 2 300 MHz), and SHF (8 025 MHz – 8 400 MHz and 8 400 MHz – 8 500 MHz) bands in the following cases:
 1. Where application of clause 6.1 can lead to power flux densities at the carrier frequency in excess of the limits specified in clause 5.5.3.
 2. In any case for symbol rates as defined by Figure 6-2 in excess of 1 Msps.
- b. For symbol rates in excess of 2 Msps (for the bands below 8 500 MHz) or 20 Msps (only for the 31,8 GHz - 32,3 GHz band) as defined by Figure 6-2, only TCM 8PSK (for the 8 025 MHz - 8 400 MHz band), filtered-OQPSK (for the bands below 8 500 MHz) or GMSK (for all bands) shall be used.

NOTE Users are encouraged to also use modulation with suppressed carrier in the range of symbol rates from 60 kbps to 1 Msps for the bands below 8 500 MHz.
- c. Data signals shall be PCM.
- d. The following modulation schemes shall be used:
 1. BPSK (binary phase shift keying);
 2. QPSK (quadrature phase shift keying);
 3. UQPSK (unbalanced quadrature phase shift keying);
 4. OQPSK (offset quadrature phase shift keying);
 5. Filtered OQPSK;
 6. GMSK (Gaussian minimum phase shift keying);
 7. TCM 8PSK (8-ary phase shift keying).
- e. In the case of new projects, modulations 1 to 4 shall only be used for symbol rates of less than 2 Msps (for the bands below 8 500 MHz) or 20 Msps (only for the 31,8 GHz - 32,3 GHz band).

¹⁶ Ranging in accordance with ECSS-E-50-02A is not compatible with this type of modulation.

¹⁷ Suppressed carrier modulation schemes for the 25,5-27,0 GHz, 37,0-38,0 GHz and 40,0-40,5 GHz bands have not been defined at the time of publication of this Standard. Users interested in the use of these bands can contact the frequency coordinator for advice.

¹⁸ Users are encouraged to consult the responsible network operation manager with regard to the capability of Earth stations to support this type of modulation and the range of symbol rates available.

6.2.2 Modulating waveforms

- a. The basic modulating PCM waveforms shall be used as per Table 6-4.
- b. If the ground stations network for the mission concerned has the capability for using the synchronization marker(s) to resolve the phase ambiguity, such techniques shall be used without performing differential encoding for BPSK, QPSK, OQPSK and UQPSK signals.
- c. If the ground stations network for the mission concerned does not have the capability to use the synchronization marker(s) to resolve the phase ambiguity, differential encoding shall be performed for BPSK, QPSK, OQPSK and UQPSK signals.
- d. In convolutionary encoded systems using conversion between NRZ-L and NRZ-M, the conversion from NRZ-L shall take place before the input to the convolutional encoder, and the conversion from NRZ-M to NRZ-L shall take place after the output from the Viterbi decoder in order to maximise performance.
- e. From a spectrum efficiency point of view, OQPSK should be used instead of QPSK.

Table 6-4: PCM waveforms

	Without differential encoding	With differential encoding
BPSK	NRZ-L	NRZ-M
QPSK	NRZ-L	Q-DNRZ (see 6.2.3.2)
UQPSK	NRZ-L	NRZ-M
OQPSK	NRZ-L	Q-DNRZ (see 6.2.3.4)
Filtered OQPSK	NRZ-L	Q-DNRZ (see 6.2.3.4)
GMSK	-	Pre-coding (see 6.2.3.5)
TCM 8PSK	-	(see 6.2.3.6)

6.2.3 Carrier modulation

6.2.3.1 BPSK

- a. The carrier shall be reversed in phase at each data signal transition.
- b. The phase angle between the two constellation points shall be $(180 \pm 2)^\circ$.

6.2.3.2 QPSK

- a. The modulation shall be phase reversal keying of two phase quadrature carriers of equal amplitude by data channels with equal symbol rates with the constellation bit mapping of Figure 6-3.
- b. The phase angle between the two quadrature carriers shall be $(90 \pm 5)^\circ$.
- c. The amplitude imbalance between the two quadrature carriers shall be less than 0,5 dB.

- d. Modulation shall be such that for each channel, the suppression of the signal from the other channel is more than 21 dB.
- e. The symbol clocks shall be synchronized to within $\pm 2\%$ of the symbol period or 1 ns, whichever is larger.
- f. In cases when Q-DNRZ differential encoding is used to remove phase ambiguity and I/Q channel reversal at the receiver side, the following differential encoding equations shall be used:

$$A_n = \overline{E_1} \overline{E_2} A_{n-1} + E_1 \overline{E_2} B_{n-1} + \overline{E_1} E_2 B_{n-1} + E_1 E_2 \overline{A_{n-1}}$$

$$B_n = \overline{E_1} E_2 B_{n-1} + E_1 \overline{E_2} A_{n-1} + \overline{E_1} \overline{E_2} A_{n-1} + E_1 E_2 \overline{B_{n-1}}$$

where,

E_1 and E_2 represent the two data streams at the input of the differential encoder;

E_1 refers to the I-channel and E_2 to the Q-channel;

A_n and B_n represent the data streams at the output of the differential encoder at time n ;

A_{n-1} and B_{n-1} represent the output data streams at time $n-1$ (one symbol time before);

A_n refers to the I-channel and B_n to the Q-channel;

The parameters with a "bar" above represent the Boolean inverse;

The two streams A_n and B_n are used as I and Q in Figure 6-3.

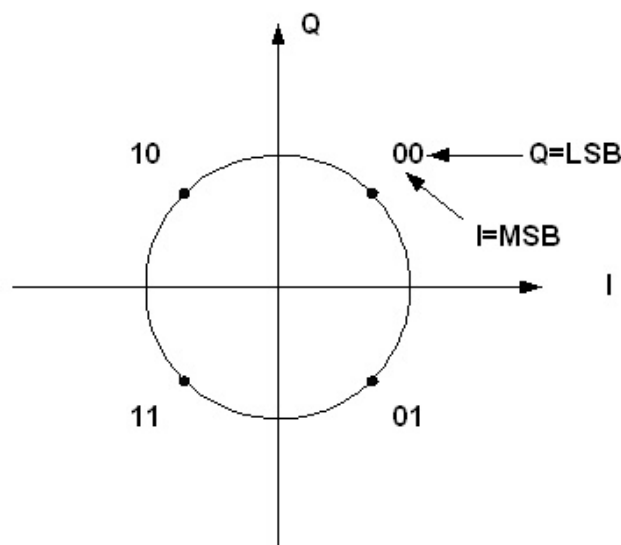

Figure 6-3: QPSK/OQPSK constellation mapping

6.2.3.3 UQPSK

- a. The data shall consist of two channels with different symbol rates and the modulation shall be phase-reversal keying of two-phase quadrature RF carriers with different amplitude.
- b. The phase angle between two quadrature carriers shall be $(90 \pm 5)^\circ$.
- c. The deviation from the theoretical amplitude imbalance between the two quadrature carriers shall be less than 0,5 dB.
- d. Modulation shall be such that for each channel, the suppression of the signal from the other channel is more than 21 dB.
- e. The symbol rate imbalance shall be more than 0,05.

NOTE The symbol rate imbalance is given by the equation:

$$\frac{R_{S1} - R_{S2}}{R_{S1} + R_{S2}}$$

where R_{s1} is the symbol rate of channel 1 and R_{s2} the symbol rate of channel 2.

- f. The power imbalance shall be in the range 4 dB to 10 dB.

6.2.3.4 Filtered and unfiltered OQPSK

- a. The modulation shall be phase reversal keying of two phase quadrature carriers of equal amplitude by data channels with equal symbol rates with the Q-channel delayed by half a channel symbol period (being the channel symbol period $T_{chs} = 2 T_s$) with regard to the I-channel, and resulting in the constellation of Figure 6-3.
- b. The phase angle between the two quadrature carriers shall be $(90 \pm 5)^\circ$.
- c. The amplitude imbalance between the two quadrature carriers shall be less than 0,5 dB.
- d. Modulation shall be such that for each channel, the suppression of the signal from the other channel is more than 21 dB.
- e. The symbol clocks shall be synchronized to within $\pm 2\%$ of the symbol period or 1 ns, whichever is larger.
- f. In case differential encoding is used, the convention for OQPSK shall be as follows:

$$\begin{aligned} p_{2n} &= a_{2n} \oplus q_{2n} & (p_{2n+1} &= p_{2n}) \\ q_{2n+1} &= b_{2n+1} \oplus \overline{p_{2n+1}} & (q_{2n+2} &= q_{2n+1}) \end{aligned}$$

The stream of symbols c_k , each one of duration T_s is the input to the differential encoder. c_k is split into two different steams a and b , each one of duration T_{chs} such that:

$$\begin{aligned} a_{2n} &= c_{2k} \\ b_{2k+1} &= c_{2k+1} \end{aligned}$$

The streams p_{2n} and q_{2n+1} are the outputs of the differential encoder and the inputs to the OQPSK modulator.

NOTE 1 In order to provide a better understanding on the implementation of the differential decoding, equations for the decoder are proposed below.

Decoder equations:

$$\begin{aligned} \hat{a}_{2n} &= \hat{p}_{2n} \oplus \hat{q}_{2n} & (\hat{a}_{2n+1} &= \hat{a}_{2n}) \\ \hat{b}_{2n+1} &= \overline{\hat{p}_{2n+1}} \oplus \hat{q}_{2n+1} & (\hat{b}_{2n+2} &= \hat{b}_{2n+1}) \end{aligned}$$

where \hat{p}_{2n} and \hat{q}_{2n} are the outputs of the demodulator and the inputs to the differential decoder.

The stream of symbols at the output of the differential decoder \hat{c}_k is either given by:

$$\hat{c}_{2k} = \hat{a}_{2k} \quad \text{and} \quad \hat{c}_{2k+1} = \hat{b}_{2k+1}$$

or

$$\hat{c}_{2k} = \hat{b}_{2k} \quad \text{and} \quad \hat{c}_{2k+1} = \hat{a}_{2k+1}$$

depending on the ambiguity in the phase and sampling time delay in the receiver. In both cases the output data stream \hat{c}_k is the same.

NOTE 2 The sign $\hat{\cdot}$ denotes an estimate of the variable. If there are no transmission errors, then $\hat{c}_k = c_k$ (where c_k is the original symbol stream input to the differential encoder).

g. If filtering is used, it shall be performed as follows:

1. For very high data rates in the 8 025 MHz – 8 400 MHz band when the hardware used does not support baseband shaping, post-amplifier shaping using a filter located at the output of the non-linear power amplifier as described in 6.2.3.4l.
2. For all other cases, square-root raised-cosine (SRRC) baseband shaping filter with roll-off factor α of 0,5 located prior to the modulator as described in 6.2.3.4i, 6.2.3.4j and 6.2.3.4k.

h. If filtering is used, the pre-detection filter (matched filter) in the receiver shall be an SRRC baseband shaping filter with roll-off factor α of 0,5 as described in 6.2.3.4i, 6.2.3.4j and 6.2.3.4k.

i. The baseband SRRC filter shall have the normalized transfer function given by:

$$\begin{aligned} H(f) &= 1 & \text{if } |f| < f_N(1-\alpha) \\ H(f) &= \sqrt{\frac{1}{2} + \frac{1}{2} \sin \left\{ \frac{\pi}{2f_N} \left(\frac{f_N - |f|}{\alpha} \right) \right\}} & \text{if } f_N(1-\alpha) \leq |f| \leq f_N(1+\alpha) \\ H(f) &= 0 & \text{if } |f| > f_N(1+\alpha) \end{aligned}$$

where

$$f_N = 1/(2T_{chs}) = R_s/4 = R_{ES}/4$$

is the Nyquist frequency.

NOTE The non-normalized value of $H(f)$ can be obtained multiplying its normalized value by $\sqrt{T_{chs}}$.

- j. The impulse response of the SRRC filter shall be given by:

$$h(t) = \frac{4\alpha}{\pi\sqrt{T_{chs}}} \frac{\cos[(1+\alpha)\pi(t/T_{chs})] + \frac{\sin[(1-\alpha)\pi(t/T_{chs})]}{4\alpha(t/T_{chs})}}{1 - [4\alpha(t/T_{chs})]^2}$$

- k. In the case of digital implementation, the FIR filter impulse response shall be at least 16 bits long.
- l. The post-amplifier filtering should be obtained with a 4 poles/2 zeros elliptic filter characterized with the normalized transfer function given in Figure 6-4.

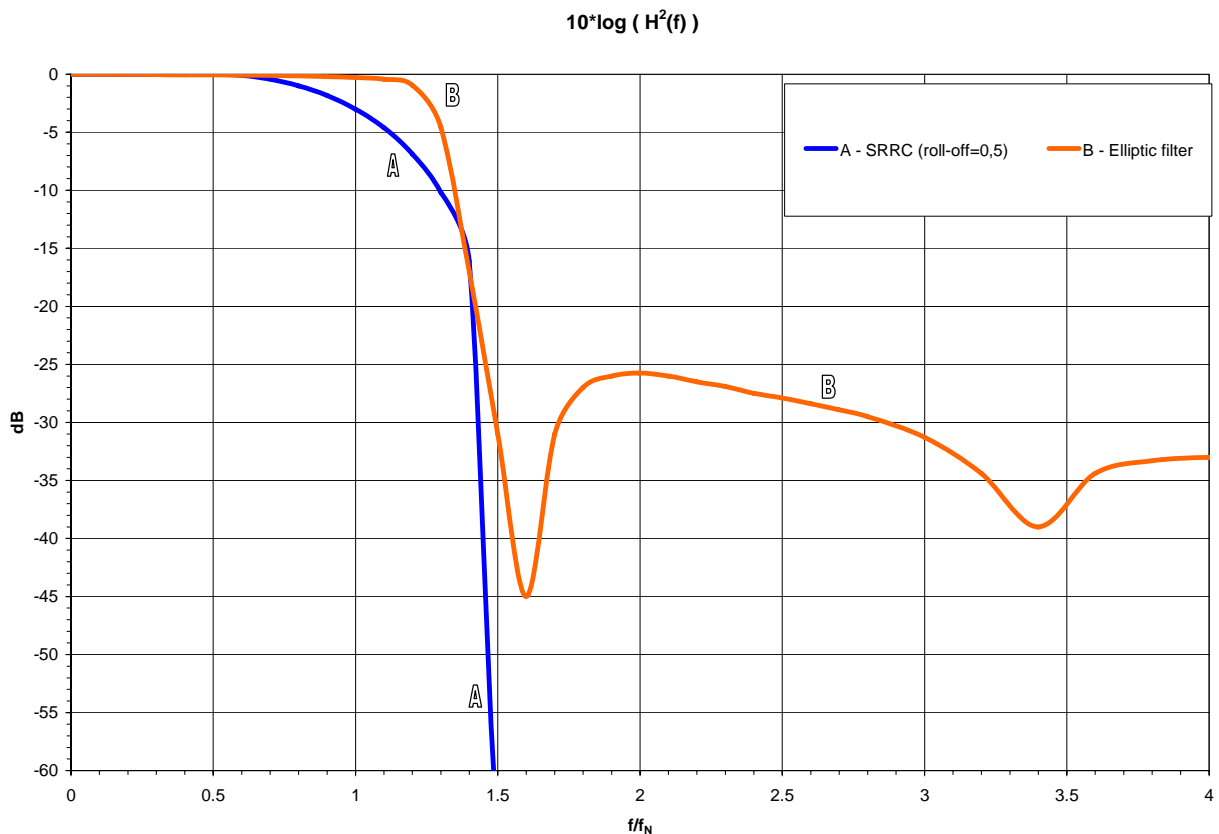

Figure 6-4: OQPSK post-amplifier filter transfer function

6.2.3.5 GMSK

- a. The GMSK modulation format shall be as described in 9.1.

NOTE The NRZ-L source symbols are pre-coded prior to modulation.
- b. For category A applications and for the 8 025 MHz – 8 400 MHz band, a $BT_s = 0,25$ shall be used together with pre-coding where:

B = one-sided 3-dB bandwidth of the filter;
 T_s = symbol duration in accordance with Figure 6-1 and Figure 6-2.
- c. For category B applications, a $BT_s = 0,5$ shall be used together with precoding where:

B = one-sided 3-dB bandwidth of the filter;
 T_s = symbol duration in accordance with Figure 6-1 and Figure 6-2.
- d. In the case of impairments the following conditions shall be met:
 1. For an I-Q implementation of the modulator:
 - (a) A phase angle between the two quadrature carriers of $(90 \pm 5)^\circ$.
 - (b) An amplitude imbalance between the two quadrature carriers of less than 0,5 dB.
 - (c) A modulation such that for each channel, the suppression of the signal from the other channel is more than 21 dB.
 2. For any implementation, a synchronization of the symbol clocks within $\pm 2\%$ of the symbol period or 1 ns, whichever is larger.
 3. For digital implementation:
 - (a) A FIR filter impulse response of at least 4 bits long for category B applications and 5 bits long for category A applications.
 - (b) A minimum number of bits for the FIR coefficient quantization of 12.

6.2.3.6 4 dimensional 8PSK–TCM

- a. The modulation format shall be as described in 9.2.

NOTE The NRZ-L input symbols are encoded differentially and convolutionally by the 4-dimensional 8PSK-TCM modulator.
- b. The phase angle between any two adjacent phase states shall be $(45 \pm 1,5)^\circ$ peak.
- c. The amplitude imbalance between any two adjacent phase states shall be less than 0,3 dB peak.
- d. The carrier rejection shall be at least 30 dB.
- e. The side-band signal rejection shall be at least 30 dB, assuming, in the case of a linear modulator, a power variation of 6 dB in the modulating signal around the mean value.

6.2.4 Data transition density

- a. To ensure recovery of the symbol clock by the ground demodulators, a pseudo-randomizer in conformance with ECSS-E-ST-50-01 clause 9 shall be used.

6.2.5 Symbol rate stability

- a. The telemetry symbol rate shall be within $\pm 1 \times 10^{-4}$ of its nominal value at all times.
- b. The telemetry symbol rate variation due to power-supply voltage, temperature and other spacecraft influences shall be less than $\pm 1 \times 10^{-5}$ over any 5 minutes period.
- c. The telemetry symbol rate short-term variation shall be less than $\pm 1 \times 10^{-6}$, over any time period less than or equal to 100 times the symbol duration.

6.2.6 Carrier phase noise

- a. The phase noise of the unmodulated carrier shall be measured in non-coherent mode.
- b. Phase noise of the unmodulated carrier, integrated between 100 Hz and 1 MHz shall be less than 2° r.m.s. at UHF for the 2 200 MHz – 2 300 MHz band.
- c. Phase noise of the unmodulated carrier, integrated between 100 Hz and 1 MHz shall be less than 6° r.m.s. at SHF for the 8 025 MHz – 8 500 MHz band.
- d. Phase noise of the unmodulated carrier, integrated between 100 Hz and 1 MHz shall be less than 10° r.m.s. at EHF for the 25,5 GHz – 27,0 GHz and 31,8 GHz – 32,3 GHz. bands.
- e. If specifications 6.2.6b, 6.2.6c and 6.2.6d are not met over the indicated integration ranges, integration shall be carried out taking into account the mission selected loop bandwidths and symbol rates.

6.2.7 Carrier suppression, out-of-band emission and discrete spectral lines

- a. The carrier suppression shall always be greater than 30 dBc.
- b. Discrete lines in the transmitted RF signal spectrum, caused by baseband or RF bandwidth limitations, non-linearity of the channel, or any other effects shall be less than -45 dBc inside the occupied bandwidth.
- c. Modulation shall not result in the introduction of lines with power greater than -30 dBc in the occupied bandwidth.
- d. The out-of-band emission due to the modulation shall conform to the spectral roll-off of clause 6.3.

6.3 Spectral roll-off

- a. The emitted telemetry spectrum for all Space Science services projects, which utilize space-to-Earth link frequency assignments in the bands 2 200 MHz - 2 290 MHz, 8 025 MHz - 8 400 MHz, or 8 450 MHz - 8 500 MHz with symbol rates R_s higher than 60 ksp/s shall adhere to the spectral emission masks of Figure 6-5 when measured at the reference point shown in Figure 6-2, where R_{ES} is as follows:
 - b. For SP-L modulation, two times the NRZ symbol rate R_s , reciprocal of the symbol duration defined in Figure 6-1 and Figure 6-2 ($R_{ES} = 2 \times R_s$).
 - c. For 8PSK TCM modulation, includes the overhead due to the signal processing up to the constellation mapper output (see Figure 9-1 and 9.2.6.2b).
 - d. In any other case, equal to R_s , reciprocal of the symbol duration defined in Figure 6-1 and Figure 6-2.

NOTE 1 See Figure 6-1 and Figure 6-2 for symbol rate definition.

NOTE 2 The emitted spectrum is measured relative to the peak of the telemetry spectrum and excluding all spurious emissions.

NOTE 3 None of the bands 2 200 MHz - 2 290 MHz, 8 025 MHz - 8 400 MHz, or 8 450 MHz - 8 500 MHz, is allocated to space research deep space missions.

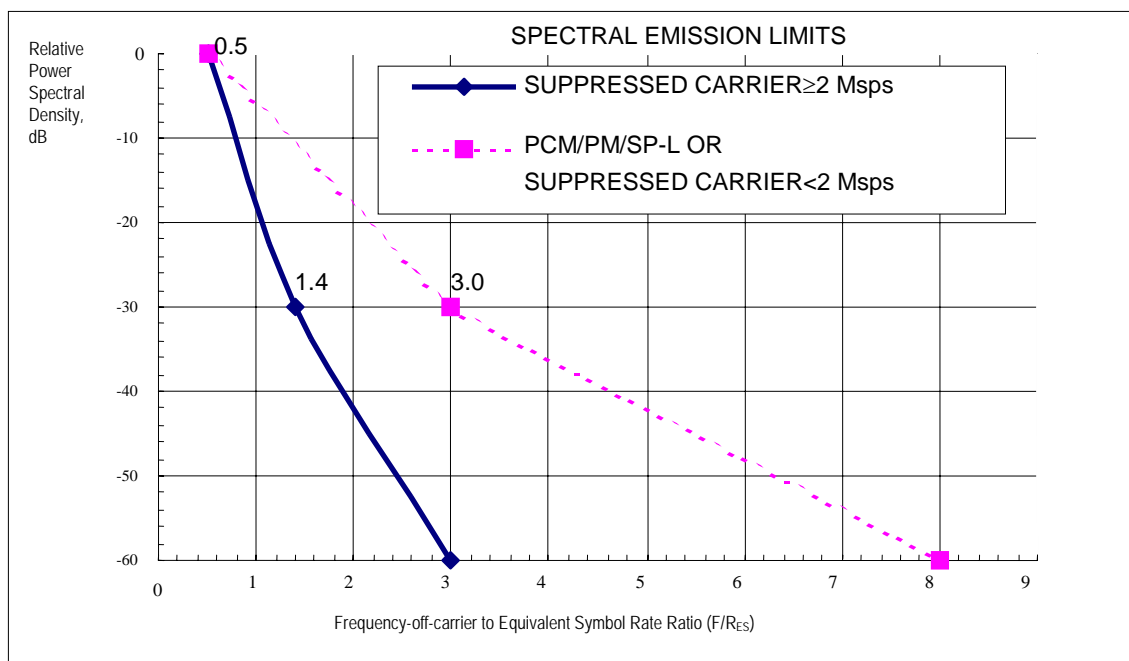

Figure 6-5: Spectral emission masks for telemetry transmission at symbol rates above 60 ksp/s

7

Link acquisition procedures

7.1 Space-Earth

7.1.1 Normal operation

7.1.1.1 Overview

- a. Under normal operation, the spacecraft transmitter is switched on by on-board automation at the time of scheduled commencement of the satellite “pass”, and the space-Earth link is modulated with the telemetry signal, containing at least the satellite housekeeping data.

7.1.1.2 Requirement

- a. For safe acquisition, a period of time commensurate with a triangular frequency search in the worst case condition on link margin shall be allowed.

NOTE This is independent of the methods used for the acquisition of the Earth station receivers and demodulators.

7.1.2 Alternative mode of operation

- a. As a secondary mode of operation, the spacecraft transmitter shall have capability to be activated by telecommand.
- b. The telecommand referred in 7.1.2.a should be issued after the frequency sweep referred to in 7.2.

7.1.3 Coherent mode

- a. If the coherent mode of the spacecraft transmitter is used, this shall be activated automatically or by telecommand, in the latter case, after acquisition of the Earth-space link is confirmed.
- b. When the status of the transponder changes between coherent and non-coherent, and the resulting frequency step in the space-Earth link causes a loss of telemetry, a new acquisition of the space-Earth link shall be performed.

7.2 Earth-space

7.2.1 2 025 MHz - 2 110 MHz category A

- a. During acquisition, no data or subcarrier modulation shall be present on the RF carrier transmitted by the ground station.
- b. The carrier shall be swept in frequency with a symmetrical triangular waveform, i.e. the frequency shall be linearly swept around a centre frequency, with suitable amplitude and shall be phase continuous.
- c. After a single sweep the frequency shall return to the centre value.
- d. If Doppler compensation is used, then Doppler shift predictions with an error of 5 kHz maximum shall be available at the station.

NOTE The centre frequency can be offset from the assigned value to compensate for Doppler shift and, if this information is available, for drift of the transponder local oscillator.

- e. The sweep amplitude shall be selected to:
 1. ensure sweeping over the transponder best lock frequency;
 2. remain inside the transponder tracking range.
- f. The lock status of the transponder shall be transmitted in the spacecraft telemetry data for operational use by the Earth station.

NOTE A standard location of the transponder lock status telemetry is specified in the Command Link Control (CLCW) as described in clause 6.3 of ECSS-E-ST-50-04.

- g. After receipt of the confirmation of lock, the Earth station shall bring the carrier frequency to the assigned value.
- h. All frequency excursions shall take place at a constant rate, selected such that the transponder phase-lock loop has no difficulty acquiring the carrier and tracking the sweep.
- i. Any frequency discontinuities and jumps shall be smaller than 1/100 of the transponder PLL lock-in range.
- j. The following values, consistent with a transponder second order phase-lock loop bandwidth $2 B_L = 800$ Hz and a damping factor $0,7 < \xi < 1,2$, should be used:
 1. Maximum sweep rate: 32 kHz/s.
 2. Maximum discontinuity: 10 Hz.
 3. Maximum sweep range: ± 150 kHz.
- k. The Earth station design should be such that it can support transponders with other PLL loop bandwidths.

NOTE This can be achieved by including flexibility on the parameters given in 7.2.1j.

- l. Onboard demodulators shall not use frequency sweep for subcarrier (when present) or bit clock acquisition.
- m. Subcarrier (when present) and bit clock acquisition shall be achieved using the preamble transmitted before all uplink messages.

NOTE The idle sequence as specified in clause 9.2.3 of ECSS-E-ST-50-04 is transmitted at all times (except during acquisition) to limit the power spectral density from the Earth transmitters.

7.2.2 2 110 MHz - 2 120 MHz category B

- a. The acquisition procedure shall be the same as that described in 7.2.1 for 2 025 MHz - 2 110 MHz, except that Doppler compensation of the uplink carrier frequency is performed and that the carrier frequency is not brought to the assigned value after acquisition.
- b. The compensation for Doppler shift and transponder local oscillator drift shall be corrected with a periodicity that ensures that the received frequency remains within ± 5 kHz of the estimated best lock frequency.

NOTE Further frequency corrections need not be performed (such as the continuous compensation of Doppler shift).

- c. To provide a means of estimating the best lock frequency, the transponder PLL error voltage (loop stress) shall be transmitted to the ground via the spacecraft telemetry.
- d. The resolution of this information shall correspond to frequency steps of the order of the PLL bandwidth ($2 B_L$) or less.
- e. The Earth station shall have capability to support a continuous frequency sweep with the following specifications:
 1. Sweep rate: 1 Hz/s to 10 kHz/s.
 2. Sweep range: ± 100 Hz to ± 300 kHz.

7.2.3 7 145 MHz - 7 190 MHz category B

- a. The acquisition procedure shall be the same as that described in 7.2.2, except that the sweep parameters are:
 1. Sweep rate: 1 Hz/s to 10 kHz/s.
 2. Maximum sweep range: ± 1 MHz.

7.2.4 7 190 MHz – 7 235 MHz category A

- a. The acquisition procedure shall be the same as that described in 7.2.1, except that the sweep parameters are:
 1. Sweep rate: 100 Hz/s to 50 kHz/s.
 2. Maximum discontinuity: 1 Hz.
 3. Maximum sweep range: ± 500 kHz.

- b. The Earth station design should be such that it can enable the support of transponders with other PLL bandwidths.

NOTE This can be achieved by including flexibility on the parameters given in 7.2.4a.

8

RF interface control

8.1 RF interface control documents

The following two documents cover the RF interface control between spacecraft and Earth stations:

- Spacecraft-Earth station interface control document.
- Link budget tables.

These documents are specified in detail in the subsequent clauses. The first document controls the RF interface. The second document is updated regularly to keep track of the development of the spacecraft and Earth station. Hardware interface compatibility is demonstrated by spacecraft-Earth station compatibility tests, which are documented in the following:

- The compatibility test plan.
- The compatibility test results.

8.2 Spacecraft-Earth station interface control document

8.2.1 Overview

The spacecraft-Earth station interface controls all the relevant parameters describing the interface between the spacecraft and the Earth stations.

8.2.2 Process

- a. The first draft of the document shall be prepared in the Phase B (preliminary definition) of the project by the responsible engineering department using inputs from the study or project manager.
- b. The document referred in 8.2.2.a. shall contain all the relevant parameters for any new ground systems to be developed for the project and for the computation of the link budget.
- c. When the definitive spacecraft parameters are specified, the final version of the document should be produced and agreed upon by the project manager and the duly appointed representative of the network operations manager.

- d. From the time the final version of the document is produced on, the document shall be under the control of the project manager, who shall agree with the responsible engineering department any changes to the parameters.
- e. The spacecraft-Earth station interface control document shall be established in conformance with the DRD in Annex A.
- f. The spacecraft-ground network interface control document shall act as a source document for all data to be used in the preparation of the link budget tables.

8.3 Link budget tables

8.3.1 General

- a. Link budget tables shall be prepared by the spacecraft project responsible for the correct modelling of all aspects of the links between spacecraft and Earth stations.
- b. The link budget tables shall be used throughout the course of the project to monitor the quality of the spacecraft-Earth network interface and be subject to verification by the engineering department responsible.
- c. Although the exact format may vary from application to application, the same terminology and parameters shall be used.

NOTE For this purpose, the terminology and parameters of the telecommunication link design control table in CCSDS RF & Modulation Blue Book, CCSDS 401.0-B, Recommendation 4.1.2 are used with exception of the layout.

8.3.2 Parameters

- a. Separate link budgets should be produced for all different parameter combinations (e.g. different Earth stations, different spacecraft antennas, and bit rates).
- b. For a given set of parameters the link budget should be evaluated for the planned maximum distance of the spacecraft from the Earth for which these parameters are used.
- c. For each parameter entering the link budget, three values should be used:
 - 1. The design value D , which is the value of the parameter expected under nominal conditions.

2. The adverse tolerance A , which takes into consideration adverse conditions such as extreme temperatures, extreme voltages, end of life, and end of maintenance period.

NOTE The adverse tolerance is defined as the worst case of a parameter minus the design value in dB. Normally, the adverse tolerance is the value given in a design specification.

3. The favourable tolerance F , which takes into consideration best case conditions such as benign environment beginning of life, and equipment recently maintained.

NOTE The favourable tolerance is defined as the best case of a parameter minus the design value in dB. Often the favourable tolerance, particularly in the design phase of a project, represents an informed estimate on how to improve the equipment over the original design.

- d. From the design value, the adverse and the favourable tolerances, the mean value μ_i and the variance (σ_i^2), based on a particular probability density function identified in Table 8-1 for each parameter should be calculated according to the equations given in Figure 8-1 for each of the distributions represented.

Table 8-1: Probability density functions for link budgets

Earth-space	Space-Earth
Uniform probability density functions	
E/S Antenna Gain (Tx)	S/C Antenna Circuit Loss (Tx)
E/S Antenna Circuit Loss (Tx)	Polarization Loss
E/S Antenna Pointing Loss (Tx)	E/S Antenna Gain (Rx)
Polarization Loss	E/S Antenna Pointing Loss (Rx)
S/C Antenna Circuit Loss (Rx)	E/S Antenna Circuit Loss (Rx)
S/C Phase Jitter Loss (Rx)	E/S Phase Jitter Loss (Rx)
Waveform Distortion Loss	Waveform Distortion Loss
Triangular probability density functions	
S/C Antenna Gain (Rx)	S/C Antenna Gain (Tx)
S/C Antenna Pointing Loss (Rx)	S/C Antenna Pointing Loss (Tx)
S/C Carrier Circuit Loss (Rx)	E/S Demodulator/Detector Loss (Rx)
S/C Demodulator/Detector Loss (Rx)	E/S Ranging Demodulation Loss (Rx)
S/C Ranging Demodulation Loss (Rx)	S/C Transmit Power (Tx)
E/S Transmit Power (Tx)	S/C Transmit EIRP (Tx)
E/S Transmit EIRP (Tx)	E/S Loop Bandwidth (Rx)
S/C Loop Bandwidth at Threshold (Rx)	E/S Lock Threshold
S/C Ranging Transponder Bandwidth (Tx)	
Gaussian probability density functions	
Atmospheric Attenuation	E/S Effective System Noise Temperature (Rx)
Ionospheric Loss	Atmospheric Attenuation
S/C System Noise Temperature (Rx)	Ionospheric Loss

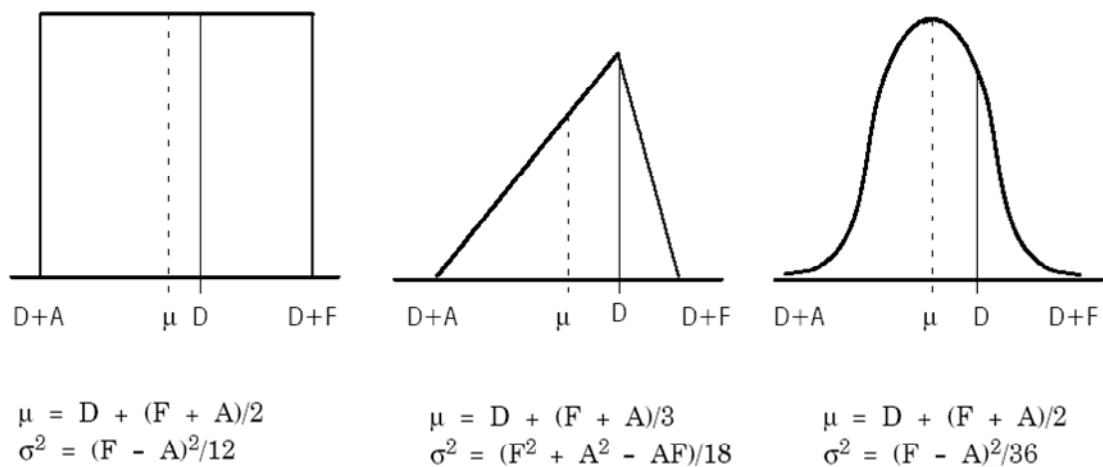
Figure 8-1: Parameter distributions and their equations

- e. Margins for budgets based on the design value, favourable tolerance, adverse tolerance, mean value, mean -3σ and worst case RSS should be calculated as follows:

1. The margin for mean -3σ is:

$$\text{margin for mean parameters} = -3\sqrt{\sum_0^n \sigma_n^2}.$$

2. The worst case RSS margin is:

$$\text{margin for design parameters} = -\sqrt{\sum_0^n A_n^2}.$$

NOTE Note that the calculation of the variances of the margin from the sum of variances of its components, which have different density functions, is valid only if all the variances are of approximately the same magnitude.

- f. If a particular variance is dominant, its statistics shall be treated separately.
- g. The jitter performance of the recovered carrier shall be included in the calculation of the degradation in the demodulation processes.
- h. Each project may have its own criteria for acceptability of link performance, using the various margins calculated in the link budget tables.
- i. Margins based on design parameters should exceed 3 dB, and those on the RSS worst case and the mean -3σ should exceed 0 dB.

NOTE These recommendations have been derived from practical experience.

- j. The link budget tables should:
1. be kept updated during the evolution of the project;
 2. reflect new information coming from the spacecraft unit, subsystem and system acceptance tests and from spacecraft-ground network compatibility tests.

8.4 Spacecraft-ground network compatibility test

- a. The compatibility of the space element and the ground stations shall be tested in conformance with requirements on “Communication compatibility test” of clauses on “Overall system qualification test” and “Overall system acceptance test” of ECSS-E-ST-10-03.

NOTE Specific ranging and Doppler tracking tests are given in clause 5 of ECSS-E-ST-50-02.

- b. Such tests shall be made with representative models of spacecraft TTC flight equipment (engineering model as a minimum) and Earth station equipment.

NOTE See also clause B.1.1.4 of ECSS-E-ST-10-02.

- c. Where new developments or extensive modifications of existing equipment are involved, preliminary tests should be made in an early phase of the programme using engineering, development or breadboard equipment.

NOTE The tests to be performed during compatibility testing vary from project to project. The purpose of the tests is always to establish thresholds and limiting values so that a good assessment of available margins can be made.

- d. A compatibility test plan, detailing as a minimum the tests to be performed, the minimum required values for critical parameters, and the spacecraft and Earth station equipment to be used, shall be drawn up before commencement of the test activities.
- e. At the conclusion of the tests, a compatibility test report, containing a formal statement on the compatibility of the spacecraft and the ground network, shall be issued by the engineering department responsible.

9

GMSK and 8PSK TCM modulation formats

9.1 GMSK modulation format

- a. The modulated RF carrier shall conform to the following expressions:

$$x(t) = \sqrt{2P} \cos(2\pi f t + \varphi(t) + \varphi_o)$$

where

P is the power of the carrier;

f is the centre frequency;

$\varphi(t)$ is the phase of the modulated carrier;

φ_o is a constant random phase;

and,

$$\varphi(t) = \sum_k \left(a_k \frac{\pi}{2} \int_{-\infty}^{t-kT_s} g(\tau) d\tau \right)$$

where

$a_k = (-1)^k d_k d_{k-1}$ are the pre-coder output symbols;

$d_k = \{ \pm 1 \}$ is the k-th information symbol to be transmitted.

The instantaneous frequency pulse $g(\tau)$ is obtained through a linear filter with impulse response defined by:

$$g(\tau) = h(\tau) * \text{rect}(\tau/T_s)$$

where

$$\text{rect}(\tau/T_s) = \begin{cases} 1/T_s & \text{for } |\tau| < T_s/2 \\ 0 & \text{otherwise} \end{cases}$$

* means convolution,

$h(\tau)$ is the Gaussian density function:

$$h(\tau) = \frac{1}{\sqrt{2\pi}\sigma T_s} \exp\left(\frac{-\tau^2}{2\sigma^2 T_s^2}\right)$$

where

$$\sigma = \frac{\sqrt{\ln(2)}}{2\pi BT_s}$$

with

$\ln(n)$ = natural logarithm (base = e);

B = one-sided 3-dB bandwidth of the filter with impulse response $h(\tau)$;

T_s = the duration of one input symbol as defined in Figure 6-1 and Figure 6-2.

NOTE The specified pre-coding suppresses the need for differential decoding at the receiver side and improves the receiver performances.

9.2 8PSK TCM modulation format

9.2.1 General principles

The MPSK-trellis coded modulation is based on the partitioning of one MPSK constellation into different subsets, each subset having a minimum Euclidian distance larger than the minimum distance of the original constellation.

With the use of a trellis coder prior to the modulator, the different phase states z_k of the constellation are not independent and belong to the coded sequences of the trellis.

The use of a maximum likelihood decoder that is sensitive to the minimum Euclidian distance d_{\min}^c offered by these sequences, gives improved performances for the data recovery in the AWGN channel.

These performances are improved by the use of multidimensional trellis coded modulation, which also allows the automatic removal of carrier phase ambiguity at demodulator side.

9.2.2 4 dimensional 8PSK-TCM encoder

- a. The 4 dimensional-8PSK trellis coded modulator shall combine a serial to parallel converter, a differential encoder, a trellis encoder, i.e. a convolutional coder, a constellation mapper and an 8PSK modulator

NOTE See Figure 9-1.

- b. The trellis encoder shall be based on a 64 state systematic convolutional encoder.

NOTE The trellis encoder is considered as the inner code if a block code is introduced.

- c. Carrier phase ambiguity shall be resolved by the use of a differential encoder located before the trellis encoder.

- d. Spectral efficiency factor (SEF) of 2 symbols/channel symbol and 2,5 symbols/channel symbol shall be achieved by one of the architectures of the constellation mapper described in 9.2.5a and 9.2.5b.

NOTE If the input data stream is paralleled into b lines, for k multidimensional 8-ary channel symbols ($k = 4$ in this case) the spectral efficiency factor of the modulation is $SEF = r = b/k$. Figure 9-1 shows the general principle of the 4D-8PSK TCM modulator.

- e. The constellation mapper shall deliver 4 parallel symbols coded with three bits to perform 8PSK modulation based on natural mapping (i.e., 0, 1, 2 ..., 7 anticlockwise).
- f. The output switch shall address successively each of the four possible channel symbols to the 8PSK modulator.
- g. The four channel symbols shall be transmitted during " b " symbol times.

NOTE The constellation rate is therefore $b/4$. At $SEF = 2$, $b = i = 8$ while at $SEF = 2,5$, $b = i = 10$. Due to the trellis encoder the number of lines at the input of the constellation mapper is $b + 1$ (either 9 or 11).

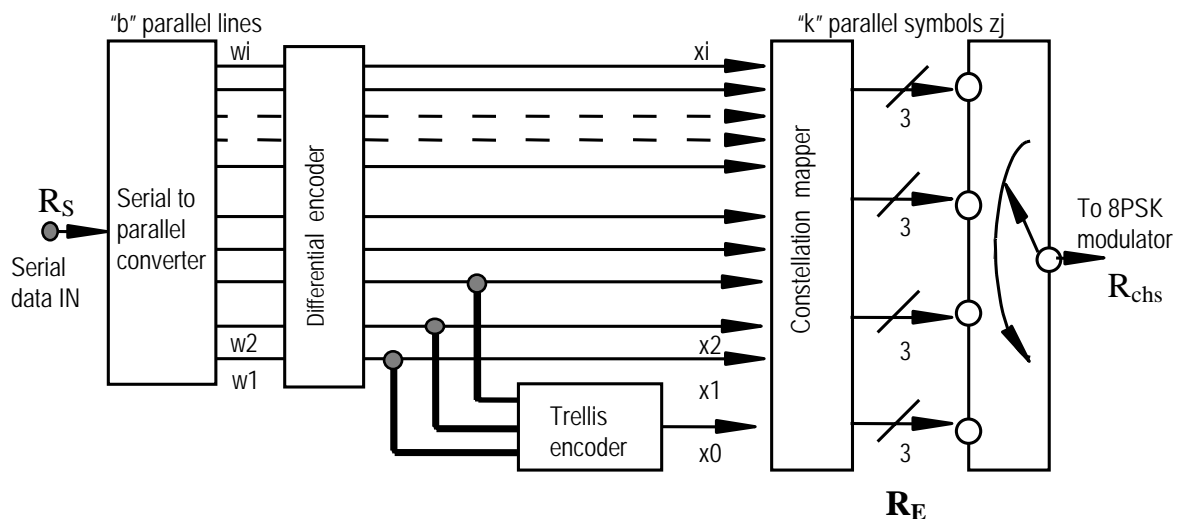

Figure 9-1: General principle of the 4D-8PSK TCM modulator

9.2.3 Differential encoders for SEF = 2 and 2,5

- a. To eliminate $22,5^\circ$ phase ambiguity on carrier synchronization, the codes represented in Figure 9-2 should be used.

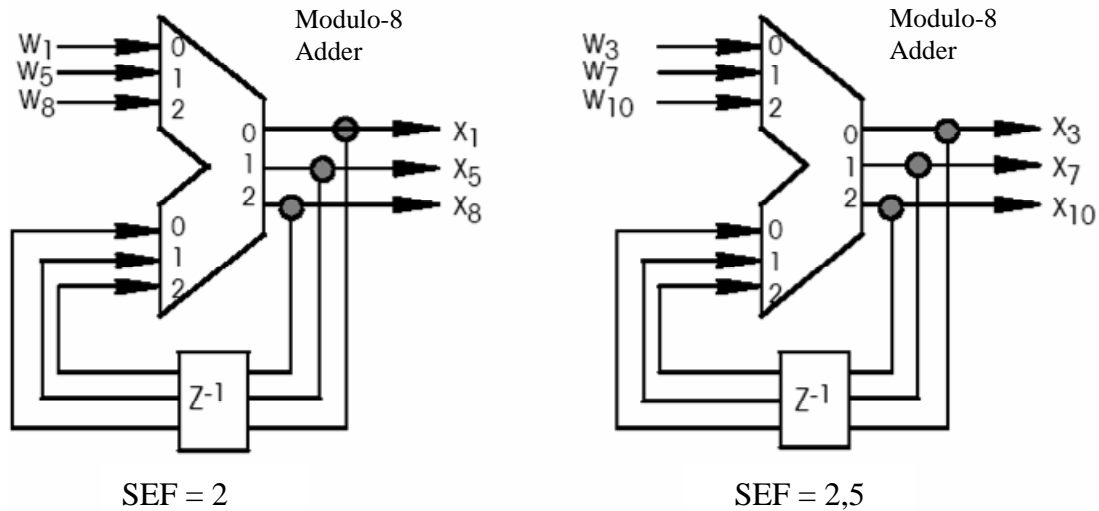

Figure 9-2: Codes to eliminate 22,5° phase ambiguity on carrier synchronization

9.2.4 Trellis encoder structure

- a. The 64 states $L = 7$, rate 3/4 systematic trellis encoder shall be as represented in Figure 9-3, which is the same encoder for both SEF values.

NOTE The corresponding polynomials (in octal) are: $h^3 = 050$, $h^2 = 024$, $h^1 = 006$, $h^0 = 103$

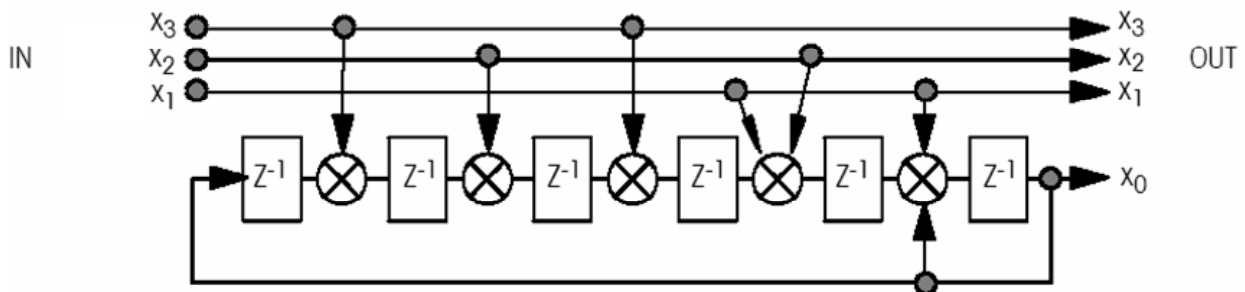
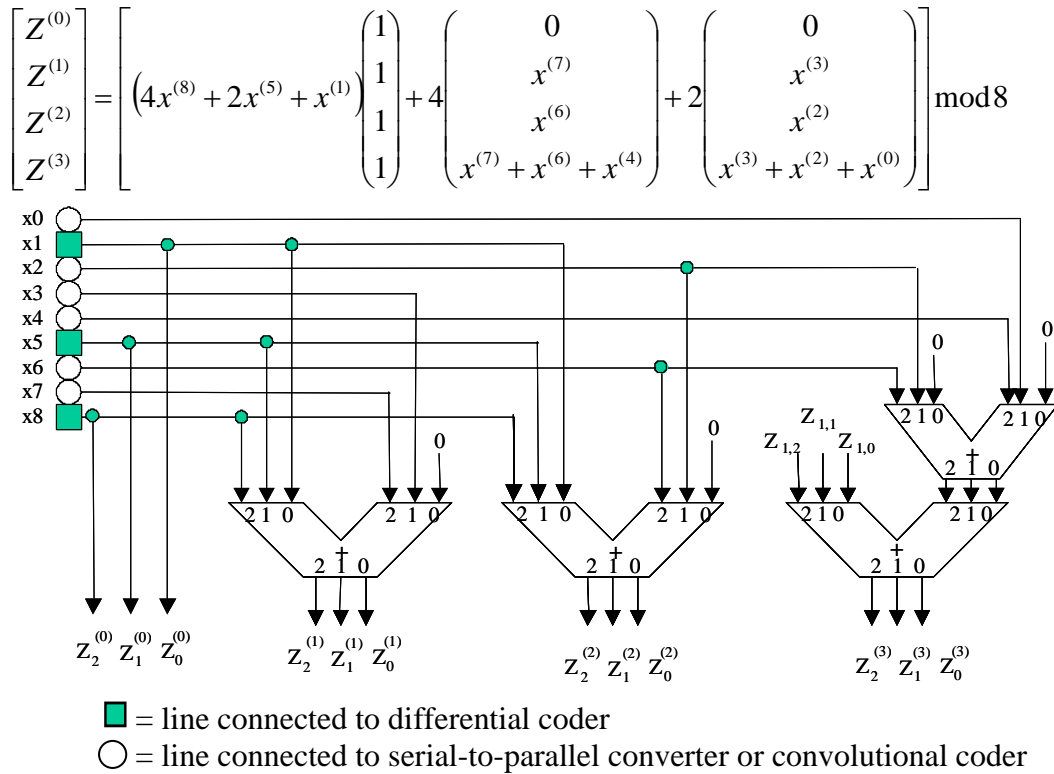
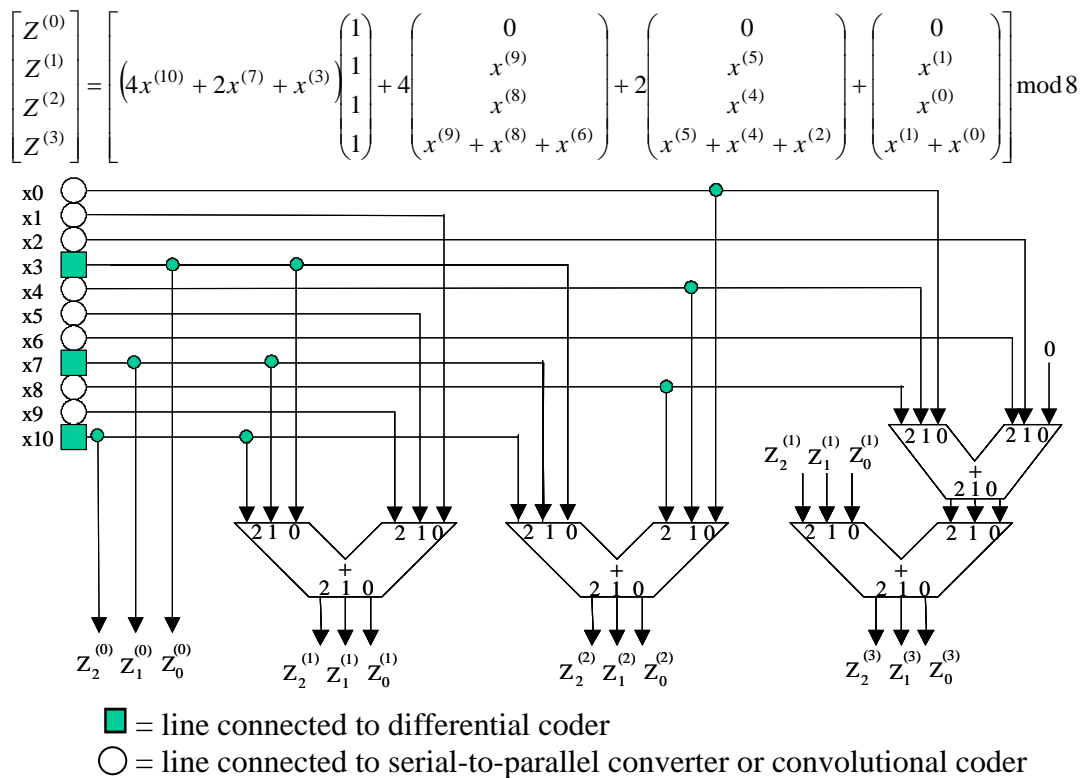

Figure 9-3: Representation of a 64 state $L=7$, rate 3/4 systematic trellis encoder

9.2.5 Constellation mapper for 4 dimensional 8PSK-TCM

- The constellation mapper for $SEF = 2$ shall conform to Figure 9-4.
- The constellation mapper for $SEF = 2,5$ shall conform to Figure 9-5.
- The channel filtering shall be obtained according to the SRRC shaping located before the linear I/Q 8-PSK modulator.
- A roll-off factor of 0,35 or 0,5 shall be used.

Figure 9-4: Constellation mapper for SEF = 2

Figure 9-5: Constellation mapper for SEF = 2,5

9.2.6 Channel filtering

9.2.6.1 General

- a. Channel filtering shall be obtained by one of the following two methods:
- Square-root raised-cosine (SRRC) baseband shaping filter located prior to the modulator, with a channel roll-off factor α of 0,35 (or 0,5) as described in 9.2.6.2.

NOTE This waveform shaping is used in association with a linear modulator and power amplifier.

- Post-amplifier shaping using an output filter located at the output of the non-linear power amplifier as described in point 9.2.6.3.

NOTE In this case a NRZ-like shaping is used in conjunction with a non-linear 8-phase modulator.

- b. In the two cases specified in 9.2.6.1 a, the pre-detection filter (matched filter) in the receiver shall be an SRRC filter with the roll-off factor α of 0,35 or 0,5.

9.2.6.2 Baseband SRRC shaping

- a. This type of channel filtering should be used for linear amplifier conditions, or with amplifier linearization, when the symbol rate to central frequency ratio is low.
- b. The normalized transfer function of the SRRC filter shall be:

$$\begin{aligned}
 H(f) &= 1 && \text{if } |f| < f_N(1-\alpha) \\
 H(f) &= \sqrt{\frac{1}{2} + \frac{1}{2} \sin \left\{ \frac{\pi}{2f_N} \left(\frac{f_N - |f|}{\alpha} \right) \right\}} && \text{if } f_N(1-\alpha) \leq |f| \leq f_N(1+\alpha) \\
 H(f) &= 0 && \text{if } |f| > f_N(1+\alpha)
 \end{aligned}$$

where

$$f_N = 1/(2 T_{chs}) = R_{chs} / 2 = R_s / XX = R_{ES}/6$$

is the Nyquist frequency and α is the roll-off factor;

and

XX is equal to 4 for SEF = 2 and to 5 for SEF = 2,5.

- c. The resulting overhead for computing R_{ES} from R_s shall be 1,5 and 1,2 for SEF = 2 and for SEF = 2,5 respectively ($R_{ES} = 1,5 R_s$ and $R_{ES} = 1,2 R_s$ respectively).

NOTE The non-normalized value of $H(f)$ can be obtained multiplying its normalized value by $\sqrt{T_{chs}}$.

- d. The corresponding transmit structure shall conform to Figure 9-6.

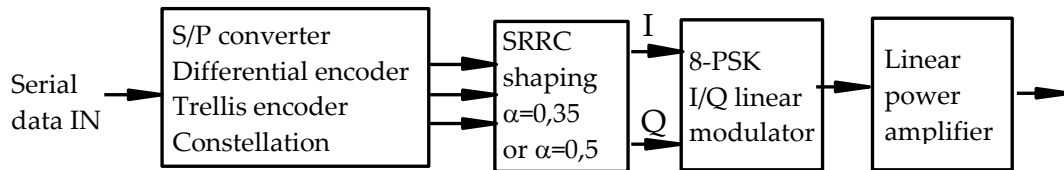

Figure 9-6: Transmit structure for baseband, square root raised-cosine shaping

9.2.6.3 Post-amplifier shaping

- a. Post-amplifier shaping should be used for nonlinear amplifier conditions or when the symbol rate to central frequency ratio is high.
- b. The output filtering should be obtained with a 4 poles/2 zeros elliptic filter characterized with the normalized transfer function given in Figure 9-7.
- c. The corresponding transmit structure should conform to Figure 9-8.

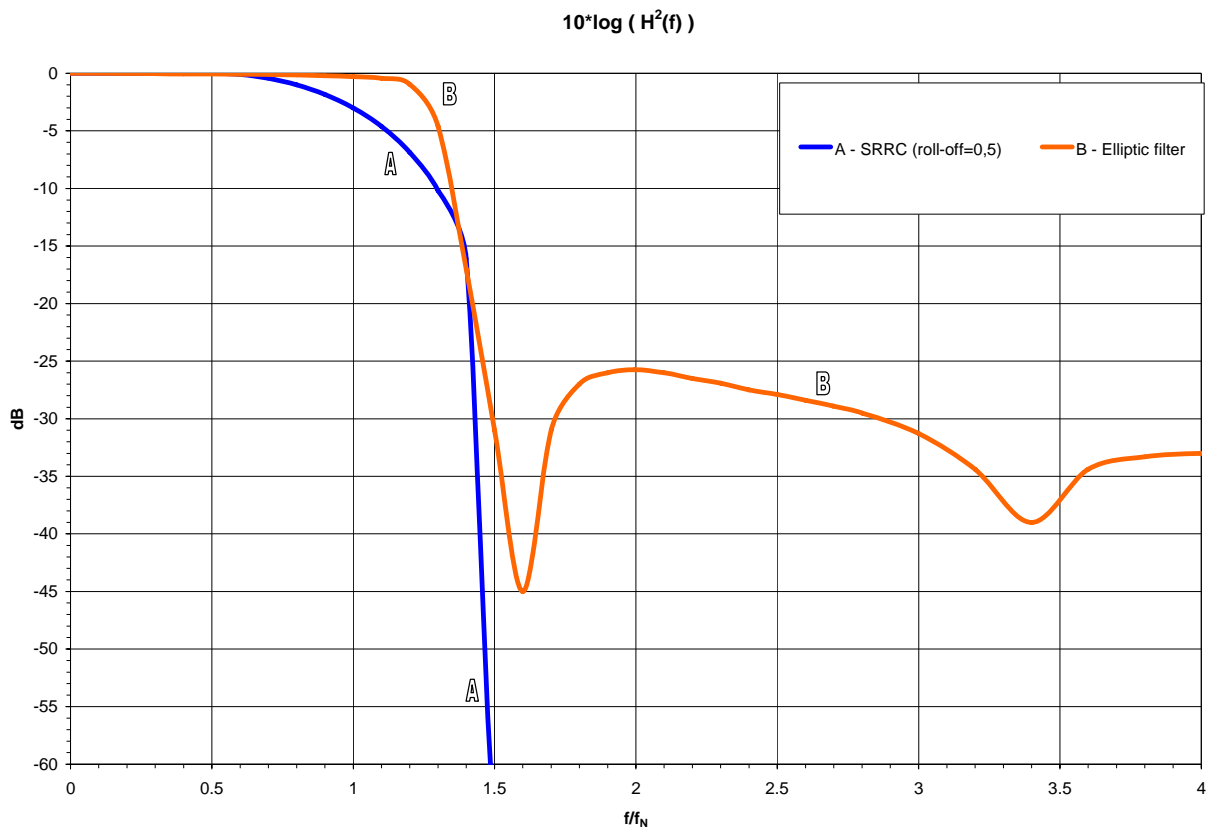

Figure 9-7: Transfer function for a 4 poles/2 zeros elliptic filter

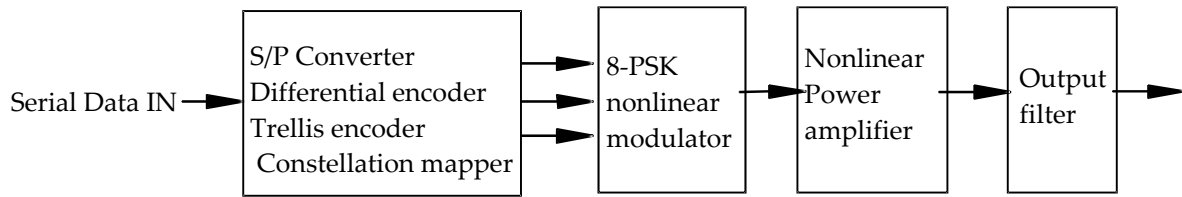

Figure 9-8: Transmit structure for post-amplifier shaping

Annex A (normative)

Spacecraft-Earth station interface control document - DRD

A.1 DRD identification

A.1.1 Requirement identification and source document

This DRD is called from ECSS-E-ST-50-05, requirement 8.2.2e.

A.1.2 Purpose and objective

The spacecraft-Earth station interface controls all the relevant parameters describing the interface between the spacecraft and the Earth stations.

A.2 Expected response

A.2.1 Contents

- a. The Spacecraft-Earth station interface control document shall include the following information:
1. Earth stations and time profile of use.
 2. Configuration of the equipment in the Earth stations and links to the control centre.
 3. Performances of Earth station (e.g. EIRP, G/T, and demodulation losses, with tolerances).
 4. Configuration of equipment on-board the spacecraft.
 5. Performances of spacecraft equipment (e.g. transmitter power, telecommand thresholds, and antenna gains, with tolerance).
 6. TTC standards applicable and any waivers granted.
 7. Choice of parameters for the links (i.e. which subsets of the parameters allowed by the standards are chosen), e.g. PCM data types, bit rates, formats, subcarriers and modulation indices.
 8. Operational modes of the spacecraft TTC subsystem (e.g. combinations of bit rates, subcarriers, formats, and indices, and combination of ranging with telecommand or telemetry).

A.2.2 Special remarks

None.

Annex B (informative)

Cross-support from other networks

B.1 Network compatibility

Compatibility of RF modulation standards between worldwide space agencies and capabilities of their Earth stations support networks are the subjects of CCSDS Recommendations for Radio Frequency and Modulation Systems (Blue Book), Part 1, Earth Stations and Spacecraft, CCSDS 401.0-B, prepared by the Consultative Committee for Space Data Systems (CCSDS)

This document provides a broad outline of the possibilities of cross-support. However, in the case of support by an external space agency, provisions are given in Annex E, requirement d.

B.2 NASA DSN compatibility

The reference document, which contains all details on the spacecraft-Earth station interface is: Deep Space Mission Systems Telecommunication Link Design Handbook (JPL document 810-005, Rev. E).

Annex C (informative)

Protection of Ariane-5 RF system

C.1 Overview

This annex does not replace the interface specifications with the Ariane-5 launcher nor the Ariane-5 launcher user guide and compatibility documentation.

C.2 Proposed conversion method for relating spurious radiation received at Ariane-5 vehicle equipment bay antennas to spurious emission requirements on payload transmitters

It is assumed that of the power produced by the payload transmitters, P_T , less than 10 % is coupled into the vehicle equipment bay via its antennas. The rest of the power is either reflected back into the transmitter or escapes via the transparent sections of the fairing.

To evaluate the relationship between the power flux density incident on the vehicle equipment bay antennas, PFD , and the power absorbed into the bay, P_R , the approximation that the antennas have 0 dBi gain can be made.

$$\text{Therefore } PFD = \frac{P_R}{G(\lambda^2/4\pi)} = 0,1 \frac{P_T}{G(\lambda^2/4\pi)}, \text{ with } G = 1 \text{ (0 dBi),}$$

$$\text{yielding: } PFD = \frac{0,4\pi P_T}{\lambda^2}$$

If free space conditions are assumed, the incident power flux density PFD can be related to the electric field at a distance D by:

$$4\pi D^2 PFD = \frac{E^2 D^2}{30}, \text{ having } PFD = \frac{E^2}{120\pi}$$

Therefore the value of P_T corresponding to a maximum permitted value of E is given by:

$$P_T = \frac{\lambda^2 E^2}{48\pi^2}$$

NOTE For example, for 20 dB ($\mu\text{V/m}$) at 435 MHz, the equivalent payload transmitter power is -100 dBm and for 70 dB ($\mu\text{V/m}$) at 5 690 MHz the equivalent payload transmitter power is -72,3 dBm.

C.3 Operating constraints

Figure C-1 contains requirements extracted from A5-SG-1-X-35-ASAI for spacecraft to be launched by an Ariane-5 vehicle.

NOTE A5-SG-1-X-35-ASAI provides the launcher susceptibility to radiated electrical field.

- a. The launcher susceptibility is directly expressed in terms of spacecraft constraint on radiated electrical field: the spacecraft shall not radiate a narrow-band electrical field at 0,5 m below the bolted interface exceeding the limit set in Table 1 (including intentional transmission).

Table 1: Maximum radiated electrical field at bolted interface

Frequency range	Field in dB(μ V/m)
14 kHz - 420 MHz	120
420 MHz - 480 MHz	35
480 MHz - 1 GHz	120
1 GHz - 2 GHz	Linear evolution from 120 dB(μ V/m) (@1 GHz) to 150 dB(μ V/m) (@2 GHz)
2 GHz - 5,45 GHz	150
5,640 GHz – 5,670 GHz	70
5,825 GHz - 20 GHz	150

- b. A 35 dB(μ V/m) level radiated by the spacecraft, in the launch vehicle telecommand receiver 420 MHz - 480 MHz band, shall be considered as the worst case of the sum of spurious level over a 100 kHz bandwidth.
- c. The field in the 5,640 GHz - 5,670 GHz band shall be measured in a resolution bandwidth of 10 MHz.
- d. The spacecraft telemetry frequency band shall not overlap the launch vehicle operational bands:
 2 203 MHz \pm 250 kHz
 2 206,5 MHz \pm 250 kHz
 2 218 MHz \pm 500 kHz
 2 227 MHz \pm 500 kHz
 2 249 MHz \pm 500 kHz
 2 254,5 MHz \pm 500 kHz
 2 267,5 MHz \pm 250 kHz
 2 284 MHz \pm 500 kHz
- e. In case the spacecraft does not conform to the constraint provided here above, case by case studies shall be conducted to verify the compatibility between launcher and spacecraft.
- f. Flight constraints during the powered phase of the launch vehicle and up to separation of the spacecraft +20 s are:
- no telecommand signal can be sent to the spacecraft,
 - spacecraft emission can not be switched on or off.

Figure C-1: Extracted requirements from A5-SG-1-X-35-ASAI

Annex D_(informative) Differences from CCSDS recommendations

D.1 Overview

This annex describes the technical differences between this Standard and the CCSDS recommendations for Radio Frequency and Modulation Systems defined in CCSDS 401.0-B-17.

NOTE CCSDS 401.0-B is made up a series of individual recommendations. As per CCSDS practice, the notation 401 (2.2.2) means recommendation 2.2.2 of 401.0-B

D.2 Differences

D.2.1 401 (2.2.3) Choice of waveforms in telecommand links

The CCSDS recommendation includes both NRZ-L and NRZ-M for Category B missions. This Standard only recommends NRZ-L for Category B missions in light of the better performance of NRZ-L.

D.2.2 401 (2.4.17A) Modulation methods for high symbol rate transmissions, Space research, Space-to-Earth, category A

The CCSDS recommendation includes FQPSK-B (Feher QPSK version B), GMSK and baseband filtered/shaped OQPSK modulations. This Standard only includes GMSK and filtered OQPSK. Furthermore, filtered OQPSK is restricted in this Standard to specific types of filter with specified roll-off factor whereas the CCSDS recommendation allows an infinite number of filters. Note, however, that these modulations are all of the quaternary offset type and are therefore interoperable.

NOTE A revision of 2.4.17A that suppresses FQPSK-B, shaped OQPSK, and certain types of filters for OQPSK is undergoing Agency review in CCSDS at the time of publication of this Standard.

D.2.3 401 (2.4.18) Modulation methods at high symbol rates transmissions, Earth exploration satellites (EES) 8 GHz band, Space-to-Earth

The CCSDS recommendation includes SRRC-4D 8PSK TCM (available options are 2,0 b/s/Hz, 2,25 b/s/Hz, 2,5 b/s/Hz and 2,75 b/s/Hz; square root raised Cosine filter with $\alpha = 0,35$ or $\alpha = 0,5$), GMSK, and filtered OQPSK (with any type of filters). This Standard only includes SRRC-4D 8PSK TCM (available options are 2,0 b/s/Hz, and 2,5 b/s/Hz; square root raised Cosine filter with $\alpha = 0,35$ or $\alpha = 0,5$), GMSK, and filtered OQPSK restricted to specific types of filter with specified roll-off factor.

NOTE SRRC-4D 8PSK TCM restriction was agreed during the drafting of this Standard ECSS-E-ST-50-05.

Annex E (informative) Tailoring guidelines

- a. If this Standard is in conflict with mission-specific requirements, deviations may be warranted, when the following is demonstrated:
 - the technical or operational need for such deviations;
 - that the intended change can be supported by existing systems.
- b. ITU/RR cannot be tailored.
- c. The tailoring process should be supported by the frequency coordinator.
- d. The project manager, prior to committing a mission to be supported by an external space agency, should verify the detailed technical documentation on the network of that agency for potential tailoring.

Bibliography

ECSS-S-ST-00	ECSS system – Description, implementation and general requirements
ECSS-E-ST-10-02	Space engineering – Verification
ECSS-E-ST-50-02	Space engineering – Ranging and Doppler tracking
ECSS-E-ST-50-04	Space engineering – Space data links – Telecommand protocols, synchronization and channel coding
ECSS-E-HB-50A	Space engineering – Communications guidelines
SFCG/HB ¹⁹ , Edition 2007	Space frequency coordination group, Hand book
SFCG Recommendation 14-1	Protection of deep space research Earth Stations from line-of-sight interference in the bands 2290-2300 MHz, 8400-8450 MHz and 31.8-32.3 GHz
SFCG Administrative Resolution A12-1R2	Establishment of procedures for inter-agency frequency coordination
SFCG Recommendation 12-4R3	Methods for reduction of potential interference between systems in the space science services in densely occupied bands
CCSDS 401.0-B-17, Edition July 2006	CCSDS Radio Frequency and Modulation Systems, Part 1: Earth Stations and Spacecraft, Blue Book
JPL document 810-005, Rev. E	JPL Deep Space Mission Systems Telecommunication Link Design Handbook ()
A5-SG-1-X-35-ASAI Edition 4, Rev 1	Specifications générales de compatibilité électromagnétique

¹⁹ For possible changes to the SFCG/HB, the interested users can contact the responsible frequency coordinator. Although the title is Hand Book, this document is a normative publication.